The Effect of the Reflective Interior Elements on the Illuminance Level in Classrooms

Pinthoko Nugroho

Master Program in Architecture, Department of Architecture, Faculty of Engineering, Universitas Atma Jaya Yogyakarta,
Thomas Aquinas Building, Jalan Babarsari 44 Yogyakarta

Article Info

Article history:

Received July 13th, 2022

Revised August 15th, 2022

Accepted August 22nd, 2022

Keywords:

Dialux Evo
Simulation
Interior
Lighting
Illuminance

ABSTRACT

Lighting is one of the essential aspects of architectural design because it is crucial for room ambiance. Artificial and natural lighting affect the architectural element and the furniture. Using simulation tools is beneficial for measuring the reflective level of furniture elements to the room's lighting. DIALux Evo3 is computer software to support artificial and natural lighting simulation for interior spaces up to a particular room standard. This study uses the DIALux Evo3 software to conduct the trial-and-error process. The level of reflection on an interior element affects the lux value. This study will focus on the aspects of the ceiling, chairs, and table furniture using the trial and error method by simulating until a difference looms. The focus simulation focuses on setting the reflective coating in the DIALux Evo3 software on ceiling elements, chairs, and tables. The literature method examines aspects of DIALux Evo3 and the points measured in the simulation process. This simulation uses 15 lamps. This study aims to prove that the choice of paint finishing affects the results produced by the vertical illuminance (adaptive) parameter and utilizes technology in architecture. The conclusion is that interior elements such as ceilings, chairs, and tables with reflective elements affect the artificial light. The aspect with low reflectivity requires a high lux value compared to architectural and interior components with high reflectance.

Corresponding Author:

Pinthoko Nugroho,
Master Program in Architecture,
Department of Architecture, Faculty of Engineering,
Universitas Atma Jaya Yogyakarta
Thomas Aquinas Building , Jalan Babarsari 44 Yogyakarta, Indonesia
Email: pintho.uajy@gmail.com

1. INTRODUCTION

Interior design focuses on existing elements in a room. The high-quality combination of lighting and furniture is crucial in creating an impressive architectural ambiance [1]. Artificial and natural lighting will emphasize design, such as color, texture, and shape. The role of natural lighting and artificial lighting is vital to determine the reflective level on the object's surface.

The usage of natural lighting in an architectural design has to be optimized [2]. Natural lighting mainly has four functions in architectural design. The first is to limit space by providing certain brightness, shape, or color to the prohibited section. The second connects the room by creating equal brightness levels to show continuity. Thirdly, by managing the level of brightness and darkness to separate space. Lastly, to create focus by breaking uniformity using unique lighting design [3]. However, the difficulty level is higher to control desired natural lighting levels inside a building, like glare and overheating.

Artificial lighting intensity and distribution are adjustable to the desired level [4]. Majority of such studies considered artificial lighting and its significance in thermal efficiency, energy consumption, and new

technology [2]. Artificial lighting has several design principles, and a reflector is important [5]. The reflector in furniture significantly impacts artificial lighting in interior design. The European Standard EN 12464 recommends reflectance for mostly interior material surfaces, i.e., walls, floors, and ceilings in indoor workplaces, to meet lighting requirements for occupants. The standard for ceiling: 0.7 to 0.9; walls: 0.5 to 0.8; floor: 0.2 to 0.4 [6].

Along with the vast and swift development of simulation programs, there are many options to analyze lighting effects on interior design, such as using the DIALux Evo. DIALux Evo is a free lighting simulation tool developed by the German Institute for Applied Lighting Technology (DIAL) intended to view simulations for artificial and natural lighting in exterior and interior spaces and to verify compliance with national and international standards. The way to the simulation is to import 2D and 3D cad files from AutoCAD and can perform calculations for any world region by selecting a location from the database or adding geographic coordinates for any day and hour [7].

For artificial lighting modeling, DIALux Evo has a database of pre-made luminaires by several manufacturers that can be added to the calculation. So, DIALux Evo can evaluate the energy requirements and efficiency of the lighting solution by providing the appropriate data for lighting analysis. DIALux Evo can simulate indoor and outdoor spaces, but this paper focuses on the interior. DIALux Evo can accommodate unique materials used in specific projects. In DIALux Evo, there are also particular parameters to achieve the illumination required by Indonesian National Standard (Standar Nasional Indonesia, SNI).

This paper aims to assess the process of simulating artificial lighting in the interior. Non-standard lighting will reduce performance and human productivity [8]. Almost every aspect of construction, such as thermal behavior, ventilation, heating, cooling, and lighting, can be modeled and assessed at the design stage, allowing corrections and maximizing building performance [2]. The ceiling is the main element influencing the spread aspect, and furniture such as chairs and tables are the main elements in artificial/natural light [9]. According to IESNA (2000), in research by Niniek Pratiwi et al. [10], there are five criteria to get a sound lighting system, and one of them is color reflection [11]. The urgency of this research is to simulate the finishing of the ceiling, chair, and table to prove the effect of the difference in the reflection factor of the two rooms.

2. METHOD

The method is a systematic trial and error using the DIALux Evo 3 and a literature study regarding the use of the DIALux Evo 3.

The more detailed profile of DIALux Evo 3 are as written below: [12][13]

- a) Live material visualization in CAD for painted and metallic materials.
- b) Faster output.
- c) Calculation of roads according to 13201 with aspects of road planning charts.
- d) Parallel planning of several schemes, e.g., different geometric shapes or arrangement of luminaires.
- e) Visualization of single luminaire lighting effects directly in CAD in real-time.
- f) Highly simplified GUI that allows simple rectangular room planning, similar to DIALux Light.
- g) Energy assessment according to EN 15193 - During planning, it is now possible to carry out an energy assessment with the option of displaying kWh/a/m², LENI (Lighting Energy Numeric Indicator), or cost in any currency of choice.
- h) Full 64-bit version – the 64-bit version is not compatible with Windows XP and cannot load old DIALux 4 projects. However, there is more storage space to deal with larger projects or during setup and can install the 32-bit version.
- i) Export HDR image.
- j) Lots of minor bug fixes.

2.1. Trial and Error Theory

Based on Thorndike's understanding that the most fundamental type of learning is the formation of associations (connections) between a sensory experience (perception of a stimulus or event) and neural impulses (responses) that provide output in the form of behavior. Thorndike believes that learning often occurs through trial and error experiments. [14]

2.2. Design strategy

The simulation for testing the ceiling, chairs, and tables is apple to apple. Aspects of the simulation and comparison process are:

- a. Setting reflective coating on ceiling elements in DIALux Evo
- b. Setting reflective coating on the seat element inside the DIALux Evo
- c. Setting reflective coating on table elements inside DIALux Evo

3. THEORIES

3.1. Lighting intensity

The unit of measurement for illuminance is the Lux, which states that light reaches a surface. The symbol for luminance intensity is E , and its unit is Lux (lx). One lumen, when the luminous flux is distributed evenly over an area of one square meter ($1 \text{ lx} = 1 \text{ lm/m}^2$), that illumination is called Lux. The range of lighting intensity in indoor lighting is 100 – 1000 lx. Illumination intensity depends on the luminous flux of the light source, optical properties, distance from the illuminated surface, and surface coloring. [15]

3.2. Luminosity

The unit of light intensity is the candela. The symbol for light intensity is I , and its unit is the candela (cd). Candela indicates the power of the light emitted. The candela value indicates how many lumens per steradian the light source emits. According to the SI system, a steradian is a number indicating the opening angle, and the entire opening angle is 4π . [15]

3.3. Luminous flux

A lumen is a unit of measurement for luminous flux/quantity of light. The symbol for luminous flux is ϕ , and its unit is lumen (lm). [15]

3.4. Lamp color curve

Find the color temperature of a fluorescent lamp in the second and third digits of the numerical value, namely 827 = 2700K, 830 = 3000K, and 840 = 4000K. [15]



Figure 1. Light Color Curve

3.5. LED

A light-emitting diode, or LED, is a semiconductor component that emits light when an electric current passes through it. LEDs are light-sensitive diodes and were first produced in 1907 under laboratory conditions and were first usable in 1962. [15] The following are some aspects that affect the simulation value of the efficiency of natural light entering the indoor space: [7]

- a. Glass; the properties of glass can respond to several aspects such as sun protection, thermal insulation, noise reduction, wind pressure, fire prevention, safety, explosion resistance, and personal hygiene.
- b. Lighting; the intensity of sunlight entering the indoor space depends on the orientation of the sun, outdoor environmental conditions, and the reflection of light that causes light to enter.
- c. Aperture (aperture); openings are architectural elements where sunlight penetrates the interior through the facade and roof.
- d. Coordinate point
- e. Time and date
- f. Illumination grid

Components affecting indoor spaces' reflections are interior surfaces (furniture, walls, floors, and ceilings) [16]. The room's shape, the selection of interior colors, and the surface pattern produce inter-reflection and lighting effects in the interior based on their scattering [16]. Interior space deals with walls, windows, doors, finishes, textures, light, furnishings, and furniture [9]. The choice of surface color, reflectance, and light distribution are the main factors in achieving an efficient interior design, one of which aims to minimize lighting energy consumption [9]. Reflectivity affects the light distribution of the light sources [9]. Studies have proven that a third of a lighting system's energy use depends on the surrounding interior features, such as ceiling height, windows, color, and surface reflectivity of the room [9]. The amount of light reflected from the surfaces is a property of light reflection value [9]. The primary reflective areas in the interior are the walls, floor, and ceiling [9]

4. RESULTS AND DISCUSSION

Based on Arto Kurvinen, the lighting intensity of the room is 100-1000 lx. This study uses an average of 825 lx. Based on Rogerio Amoeda, the aspects that affect the simulation value of the efficiency of natural light in the room are using LED lights and an illumination grid. In the light discussed by Arto Kurvinen, the number of LED lamps used was 15 units, each of which had a luminous flux of 3210 lm. Using the trial and error theory from Edward Thorndike [6], sensory experience is in the form of paint finishing results, namely: shiny or not, and the output of nerve impulses is in the form of experiments with the DIALux Evo software. Finally, based on Jitka Mohelnikova, the components that affect reflections in the interior are furniture, including ceilings, chairs, and tables that arrange become patterns. This study uses the three elements as objects for comparison and simulation. The DIALux Evo focuses on the reflective coating point.

Two 8 m x 8 m classrooms are constructed with a ceiling height of 2.8 meters. Reinhart explained that an increase in ceiling reflectance positively affects the uniform distribution of sunlight and energy savings in space [17]. The rooms in this simulation only use one door with no windows. The variables to compare are the ceiling elements and 30 units of tables and chairs. The comparison is based on the reflective coating or the level of reflection of paint finishing on chairs and tables. The three components are physical in architecture and interior with essential and primary values [17]. Surface reflectance is one of the main parameters to optimize the reflection and distribution of natural and artificial light that influences the light presented in the room [17] (Table 1). Several variables were made equal between the two test chambers. All saturation settings (R, G, B) use 212 and have no color difference. The material type is metallic, with a reflection factor of 50%. The reflective coating or surface finishing (ceiling, tables, chairs) are different. (see Table 2). This study obtained the difference in the vertical illuminance (adaptive) parameter (Table 3). Figure 2 depicts the position of the lamp, chair, table, and one door of the classroom. The display of this simulation is in Azriyenni's manual [18].

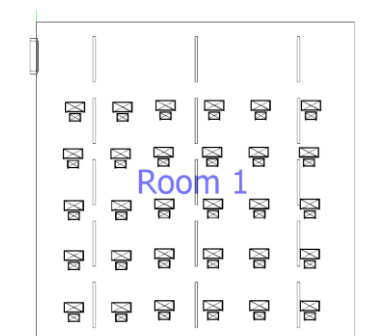

Figure 2. Furniture Layout and Classroom Lighting For Simulation 1 and Simulation 2

Table 1 shows simulation one. It has an average of 834 lx. The second simulation has a standard (lx) of 825 lx. A.Hangga et al. explained that the definite lighting in the classroom is 350-3000 lux, and the simulation results are in that range. Therefore, if the simulation results are below 350 lux or more than 3000 lux, it can affect the visual uniformity and low discomfort for the user [19].

No.	Quantity		
1	15	Petridis Lighting S.A. 132053 ARETE_LED_25W_WARM_L1140mm Light output ratio: 84.92% Luminous flux: 3210 lm, Power: 25.0 W	 
Total luminous flux: 48151 lm, Total Load: 375 W Specific connection value: 5.85 W/m ² (Ground area 64.07 m ²)			

Figure 3. Lamp Specification Detail Used In The Simulation

Table 1. Simulation Comparison

Simulation 1 (reflective 1%)

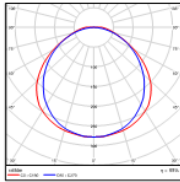
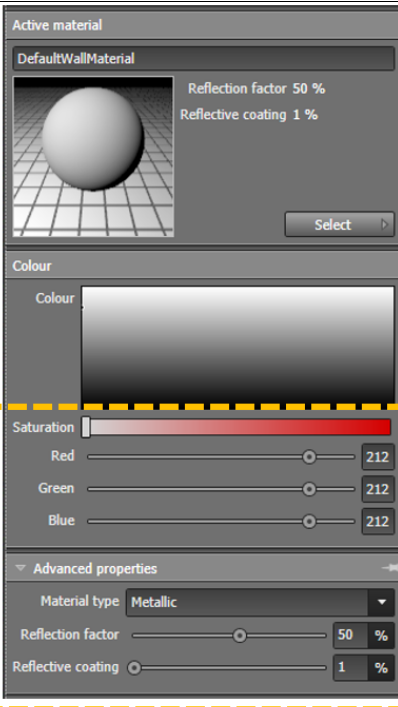

Simulation 2 (reflective 95%)

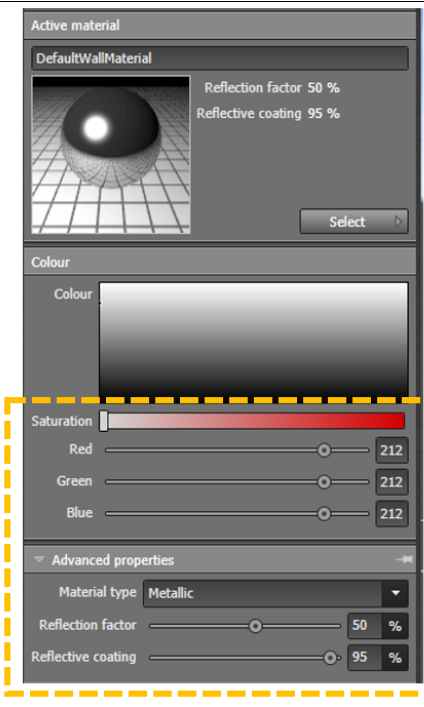

Scale: 1 : 50

Perpendicular illuminance (adaptive)

Name	Average [lx]	Min [lx]	Max [lx]	Min/average	Min/max	Points (Relevant)
Workplane 1	834	543	941	0.651	0.577	256 x 256 (65483)

Height of room: 2.800 m, Height of working plane: 0.800 m, Wall zone: 0.000 m, Reflection factors: Ceiling 56.7%, Walls 90.0%, Floor 1 Maintenance factor: 0.80

Scale: 1 : 50

Perpendicular illuminance (adaptive)

Name	Average [lx]	Min [lx]	Max [lx]	Min/average	Min/max	Points (Relevant)
Workplane 1	825	539	937	0.653	0.575	256 x 256 (65483)

Height of room: 2.800 m, Height of working plane: 0.800 m, Wall zone: 0.000 m, Reflection factors: Ceiling 56.7%, Walls 90.0%, Floor 90.0% Maintenance factor: 0.80



Figure 4. Simulation perspective 1 (reflective 1%)



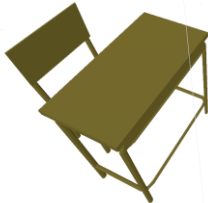

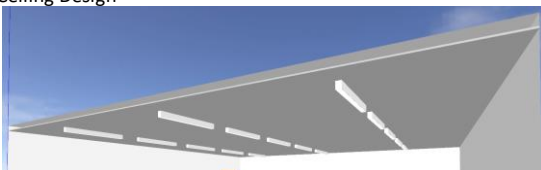

Figure 5. Simulation perspective 2 (reflective 95%)

Figure 3 describes the specs of the lamp used in this study. There are 15 units of lights, 25 watts of power per unit, with a luminous flux of 3210 lm. Arto Kurvinen's research shows that the lamp's color tends

to be yellow. In the study, a classroom with an area of 64.07 m² has a total luminous flux value of 48151 lm and a complete load of 375 Watt, so it has a value of 5.86 W/m².

The following Table 2 describes the comparison between simulation 1 (1%) and simulation 2 (95% reflective coating) :

Table 2. Comparison of Specs In Simulation 1 and Simulation 2

Simulation 1 Tables, chairs 1: With 1% reflective coating	Simulation 2 Table, chair 2: With 95% reflective coating																														
Color and application:	Color and application:																														
																															
<table border="1" style="background-color: #444; color: #fff;"> <tr> <td>Position</td> <td>4.397</td> <td>4.459</td> <td>0.140</td> <td>m</td> </tr> <tr> <td>Size</td> <td>0.500</td> <td>0.500</td> <td>0.500</td> <td>m</td> </tr> <tr> <td>Rotation</td> <td>0.0</td> <td>0.0</td> <td>180.0</td> <td>°</td> </tr> </table>	Position	4.397	4.459	0.140	m	Size	0.500	0.500	0.500	m	Rotation	0.0	0.0	180.0	°	<table border="1" style="background-color: #444; color: #fff;"> <tr> <td>Position</td> <td>4.397</td> <td>4.459</td> <td>0.140</td> <td>m</td> </tr> <tr> <td>Size</td> <td>0.500</td> <td>0.500</td> <td>0.500</td> <td>m</td> </tr> <tr> <td>Rotation</td> <td>0.0</td> <td>0.0</td> <td>180.0</td> <td>°</td> </tr> </table>	Position	4.397	4.459	0.140	m	Size	0.500	0.500	0.500	m	Rotation	0.0	0.0	180.0	°
Position	4.397	4.459	0.140	m																											
Size	0.500	0.500	0.500	m																											
Rotation	0.0	0.0	180.0	°																											
Position	4.397	4.459	0.140	m																											
Size	0.500	0.500	0.500	m																											
Rotation	0.0	0.0	180.0	°																											
<ul style="list-style-type: none"> ▪ Chairs, tables totaling 30 units ▪ Use of lamps: A total of 15 units ▪ Lamp arrangement and position: same as simulation 2 ▪ Lamp details: Arete LED 25W warm L1140mm ▪ Luminous flux: 3210 lm ▪ Connected load: 25 watts/ lamp ▪ Ceiling <p>The level of reflective coating follows the setting of the chair, table</p>	<ul style="list-style-type: none"> ▪ Chairs, tables totaling 30 units ▪ Use of lamps: A total of 15 units ▪ Lamp arrangement and position: same as simulation 2 ▪ Lamp details: Arete LED 25W warm L1140mm ▪ Luminous flux: 3210 lm ▪ Connected load: 25 watts/ lamp ▪ Ceiling <p>The level of reflective coating follows the setting of the chair, and table.</p>																														
<p>Ceiling Design</p> 	<p>Ceiling Design</p> 																														

5. CONCLUSION

Based on the experiment results and discussion shown above, the conclusions of this study are as follow:

- a. DIALux Evo became a tool to explore the level of paint reflection on interior elements in the classroom.
- b. The advantage of using DIALux Evo is that it can accurately process and simulate a room because it can include the profile of the lamp and the needs of interior materials, such as the level of reflection and absorption rate.
- c. The drawback of the simulation using DIALux Evo is the limited specs of the lamp types in the software with the specs of lamp types found on the market, but it can overcome this by selecting similar specs.
- d. The results of setting reflective coating on ceiling elements, chairs, and tables in DIALux Evo by trial and error method are in Table 3.

Table 3. Comparison of The Difference Between Simulation 1 and Simulation 2

		The difference between simulation 1 and simulation 2
Perpendicular illuminance (adaptive)	Average (lx)	9
	Min (lx)	4
	Max (lx)	4
	Min/ average	0.002
	Min/ max	0.002
	Points (relevant)	256 x 256 (65483); in simulation 1 and simulation 2 there is no change.

- e. This study proves that the choice of paint finishing on the ceiling, chairs, and tables affects the Lux results in the room.
- f. The selection of chair and table elements with glossy or matte material has a different effect on the rooms' light requirements, measured based on Lux.
- g. The choice of ceiling finishing, such as glossy or matte, gives a different effect on the room's light needs, measured based on Lux.
- h. The fewer the reflecting elements, the larger the Lux required
- i. Architectural and interior components with low reflectivity require a high lux value compared to architectural and interior features with high reflectance/ reflection.
- j. The future recommendation from this research is to open another perspective that if you want to have a goal to save on the use of artificial lighting, you can use a low level of reflection on interior elements.

REFERENCES

- [1] TCPI, "Importance of Architectural Lighting," TCPI, 2017. [Online]. Available: <https://www.tcpi.com/wp-content/uploads/2017/11/The-Importance-of-Architectural-Lighting-White-Paper-rev.pdf>. [Accessed 21 August 2022].
- [2] A. Sholanke, O. Fadesere and D. Elendu, "The Role of Artificial Lighting in Architectural Design: A Literature Review," *International Conference on Energy and Sustainable Environment*, vol. 665, pp. 1-15, 2020.
- [3] O. Kaheneko, "Research on Application of Natural Light in Modern Architecture Design," *THE INTERNATIONAL JOURNAL OF SCIENCE & TECHNOLOGY*, vol. 9, no. 2, pp. 43-56, March 2021.
- [4] A. L. Lukman, A. Mandala and C. E. Utamalie, "The role of artificial lighting techniques in forming sacred expressions at the sanctuary of the St. Laurentius Catholic Church Bandung, Indonesia," *ARTEKS*, vol. 7, no. 1, pp. 119-129, 2022.
- [5] E. H. SUTANTO, *Prinsip-Prinsip Pencahayaan Buatan Dalam Arsitektur*, Yogyakarta: Kanisius, 2017.
- [6] E. S. E. E. C. f. S. 12464, "Lighting of work places - Part 1: Indoor work places". Patent 12464, European Standard EN , 2011.
- [7] r. amoeda, "daylighting simulation on restoration project of vernacular architecture: an application of DIALux evo 9.1," *Conference: HERITAGE 2020 - 7th International Conference on Heritage and Sustainable development: Coimbra, Portugal*, vol. Volume: 1, 2020.
- [8] J. M. Katabaro and Y. Yan, "Effects of Lighting Quality on Working Efficiency of Workers in Office Building in Tanzania," *Hindawi Journal of Environmental and Public Health*, vol. Volume 2019, pp. 1-12, 2019.
- [9] R. Singh and R. Rawal, "EFFECT OF SURFACE REFLECTANCE ON LIGHTING EFFICIENCY IN INTERIORS," *Proceedings of Building Simulation 2011*, vol. 12th Conference of International Building Performance Simulation Association, Sydney, 14-16 November..
- [10] F. K. Pratiwi, E. R. Kridarso and J. Iskandar, "KONSEP PENCAHAYAAN ALAMI PADA DESAIN RUANG GALERI MENGGUNAKAN DIALUX EVO 9.2 (Studi Kasus: Desain Perancangan Gedung Pusat Pertunjukan Seni Dan udaya di Taman Mini Indonesia Indah, Jakarta Timur)," *Jurnal Arsitektur ARCADE*, vol. Vol. 5 No.3, pp. 310-315, November 2021.

- [11] N. Pratiwi and A. G. Djafar, "Analysis of Lighting Performance in the Hall of the Faculty of Engineering, State University of Gorontalo by using the DIALux Evo 9.0 Simulation," *IOP Conf. Series: Earth and Environmental Science* 738 (2021) 012032, vol. Volume 738, no. doi:10.1088/1755-1315/738/1/012032, 2021.
- [12] D.-I. (. D. Witze, "DIALux Evo – new calculation method," *DIALux Evo – New calculation method*, 2012.
- [13] "Knowledge Base DIALux Evo," April 23rd, 2021. [Online]. Available: <https://evo.support-en.dial.de/support/solutions/articles/9000115314-energy-consumption>. [Accessed July 2022].
- [14] Hermansyah, "ANALISIS TEORI BEHAVIORISTIK (EDWARD THORDINKE) DAN IMPLEMENTASINYA DALAM PEMBELAJARAN SD/MI," *MODELING: Jurnal Program Studi PGMI*, pp. Volume 7, Nomor 1, Maret 2020; p-ISSN: 2442-3661; e-ISSN: 2477-667X, 15-25, 2020.
- [15] A. Kurvinen, LIGHTING DESIGN WITH DIALUX-EVO LIGHTING CALCULATION SOFTWARE, Sähkötekniikan koulutusohjelma, March 2016.
- [16] J. Mohelnikova, "Effect of externally and internally reflective components on interior daylighting," *Elsevier*, vol. Volume 7, pp. Pages 31-37, September 2016.
- [17] N. Makaremi, S. Schiavoni, A. L. Pisello, F. Asdrubali and F. Cotana, "Quantifying the effects of interior surface reflectance on indoor lighting," *ScienceDirect Energy Procedia* 134, ELSEVIER, Vols. 9th International Conference on Sustainability in Energy and Buildings, SEB-17, 5-7 July 2017, p. 306–316, 2017.
- [18] r. f. a. h. azriyenni, teknik pencahayaan ruangan via dialux evo 8.1, Pekanbaru.
- [19] A. Hangga, . A. M. Nisa, M. Apriliyanto, M. Afandi, D. Pratama, M. A. Aziz, A. Wijanarko and S. Witrianto, "Modelling of lighting system utilizing natural and artificial lighting using DIALux," *IOP Conf. Series: Earth and Environmental Science* 969 (2022) 012024, vol. 10th Engineering International Conference, 2022.
- [20] "www.dialux.com," June 2022. [Online]. Available: (<https://www.dialux.com/en-GB/dialux/version-history>).
- [21] M. L. F. P. W. M. R. F. & P. N. Nurrohman, "Efficient Lighting Design for Multiuse Architecture Studio Classroom using Dialux Evo 9," *IOP Conference Series: Earth and Environmental Science*, 738 <https://doi.org/10.1088/1.728>, 2021.
- [22] M. H. Ahmad, Y. . Z. Arief and M. A. Kamaruddin, "Energy Analysis of Efficient Lighting System Design for Lecturing Room Using DIALux Evo 3," *Applied Mechanics and Materials* © (2016) *Trans Tech Publications, Switzerland*. doi:10.4028/www.scientific.net/AMM.818.174, vol. 818, pp. 174-178, 2016.
- [23] R. S. Saraswati, B. A. Wibawa and B. E. Saputra, "Optimization of Natural and Artificial Lighting System in UPGRIS Lecturer's Workspace using Dialux Evo," *The 20th Sustainable, Environment and Architecture*, vol. IOP Conf. Series: Earth and Environmental Science 738 (2021) 012033, 2021.
- [24] R. A. Mangkuto, "Validation of DIALux 4.12 and DIALux Evo 4.1 against the analytical test cases of CIE 171:2006," *LEUKOS The Journal of the Illuminating Engineering Society of North America*, vol. DOI: 10.1080/15502724.2015.1061438, August 2015.
- [25] V. P. Budak, T. V. Meshkova, V. Zheltov and R. S. Notfullin, "Evaluation of illumination quality based on spatial-angular luminance distribution," *Light and Engineering*, Vols. Vol. 25, No. 4, pp. 24-31, 2017, pp. No. 3, 2017, pp. 17–22, January 2017.
- [26] N. Makaremi, S. Schiavoni, A. L. Pisello, F. Asdrubali and F. Cotana, "Quantifying the effects of interior surface reflectance on indoor lighting," *ScienceDirect, Elsevier*, Vols. 9th International Conference on Sustainability in Energy and Buildings, SEB-17, 5-7 July 2017.

BIOGRAPHIES OF AUTHORS

Pinthoko Nugroho	Pinthoko attended Universitas Atma Jaya Yogyakarta for his undergraduate study. He is graduated in 2017 with a Bachelor of Architectural Engineering degree.
------------------	--