

PAPER • OPEN ACCESS

Power produced analysis of solar arrays in nadir pointing mode for low-earth equatorial micro-satellite conceptual design

To cite this article: A Z Ribah and S Ramayanti 2019 *IOP Conf. Ser.: Earth Environ. Sci.* **284** 012048

View the [article online](#) for updates and enhancements.

Power produced analysis of solar arrays in nadir pointing mode for low-earth equatorial micro-satellite conceptual design

A Z Ribah¹, S Ramayanti¹

¹Satellite Technology Center, National Institute of Aeronautics and Space (LAPAN), Bogor, Indonesia

E-mail: zammir.ribah@gmail.com, sri.ramayanti18@gmail.com

Abstract. We analyse the power produced by solar arrays in low-earth equatorial Micro-satellite conceptual design. The micro-satellite will be designed to be operated in nadir pointing mode, 1200 km of altitude, and equatorial orbit with 0 degree of inclination. Based on the profile, the mission of the satellite is operated suitably as LEO type communication satellite. To support the mission, the satellite needs to consider how much power provided from power resource; in this case, the satellite has solar arrays to obtain the power. Furthermore, the micro-satellite also has the body mounted solar array configuration, and these arrays are installed at the Z-, X+, and X- side of the satellite. However, to estimate the power output from the arrays, there are some problems that must be concerned, the first is the nadir pointing mode that makes the satellite must be pointed to nadir, and it causes the sunlight vector do not perpendicularly come into the solar arrays surface. The second problem is the sun position (equinox and solstice) that changes periodically throughout the year. Then, both can produce losses in producing power from the solar arrays. In this paper, the differences in produced power are analysed. Then the power produced in the Z-, X+, and X- sides in the two specific sun position become estimated. After that, we determine and analyse the ratio between average produced power and the maximum power produced.

1. Introduction

The capability of micro-satellite was improved in the recent years particularly as advancing technology enhancement. Moreover, the advantages of the microsatellite such as reduced launch costs, miniaturization of technology, and standardization are driving increased the interest of companies and organizations in microsatellite developments [1]. Micro satellite mostly orbits in LEO, ranging from 500 km to 1500 km, with satellite constellation systems. The satellite system consists of a constellation of many satellites in circular orbits at altitudes. The satellites can either have inclined, or polar orbits, or a combination of the two [2].

In this paper, the micro-satellite will be designed by orbit profiles for instance nadir pointing mode during operation, 1200 km of altitude, and equatorial orbit with 0 degree of inclination. These profiles are typically suitable with communication satellite mission. LEO satellite system can be well adapted to communication satellite with short delayed time communications, and can potentially perform real-time communications [3]. The nadir-pointing mode is used for directing the payload. Furthermore, according to communication mission, the antenna payload must be directly pointed to earth continuously. This satellite uses solar arrays to obtain the power from the solar energy and distributed to the components. Because of the operation mode, the satellite cannot provide the maximum power



continuously. To obtain the maximum power, the arrays must be pointed perpendicularly to the sun, in the other word the sun incidence angle is nearly zero degree. We must determine the losses that produced from the variation of sun incidence angle. Then, we can calculate the power produced from solar arrays and how much that power can support the mission.

2. Satellite Design Requirements and Limitations

The satellite orbits in low earth orbit (LEO) with 1200 km of altitude. Then, the satellite's orbit is equatorial circular with 0 degree of inclination and zero eccentricity. As mentioned before, the satellite will be operated using nadir pointing mode. Hence, the slew capability of the satellite will always allow the satellite to point at a certain object along the earth ground track [4].

With the orbital parameters that had been known, the satellite's orbit can be simulated using AGI's System Tool Kit (STK) software. The simulation gives the visualization and also generates several data that will be used in solar array/array sizing such as the daylight-eclipse durations, and Satellite-to-Sun elevation angle [5]. The captured image of simulation is shown in figure 1.

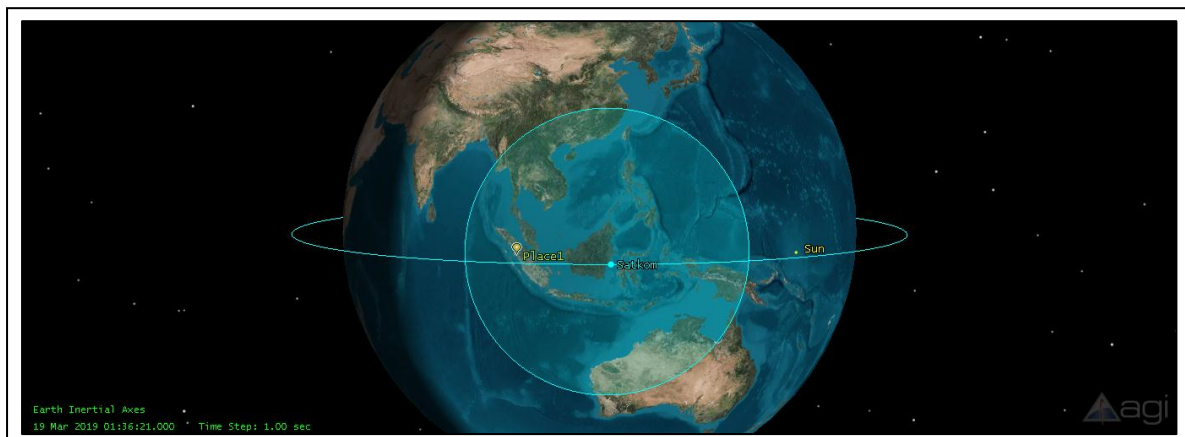

Figure 1. Visualization of satellite's orbit using AGI's System Tool Kit (STK) Software

2.1. Satellite Configuration

The configuration of solar array will affect the satellite configuration significantly. In this paper, the satellite implements the body-mounted solar array as the main configuration. The illustration in figure 2 shows a micro satellite, the LEOS-50 is a small spacecraft which allowing 15-25kg payload capacity [6], that has similar configuration with the designed satellite. Then, the solar array has conceptually designed as simplified drawing in figure 3. The solar array has size as 370 x 700 mm. Moreover, the satellite design size is limited by micro-satellite type that has limitation such as the mass under 150 kilograms and the size envelope of 700 x 700 x 850 mm [7].

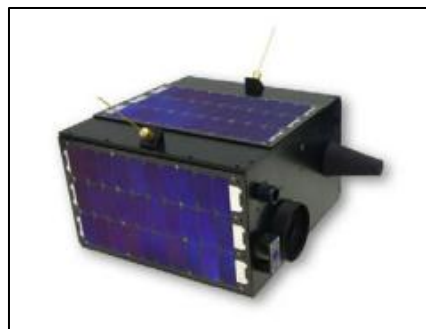

Figure 2. Small spacecraft produced by Berlin Space Technologies GmbH, The LEOS-50

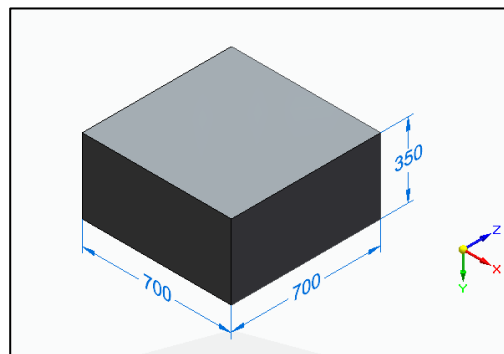

Figure 3. Satellite initial sizing based on conceptual solar array’s dimension

2.2. Sun position throughout the year

There is two sun position, both are the sun position exactly above the equator line (Equinox) and the time when the sun at the farthest position from the equator line (Solstice) [8]. In each year, the equinox would occur on March, 20 and September, 22. Then, the solstice would occur on June, 21. In figure 4, The earth's equator is tilted 23.45 degrees with respect to the plane of the earth's orbit around the sun, so at various times during the year, as the earth orbits the sun, declination varies from 23.45 degrees north to 23.45 degrees south.

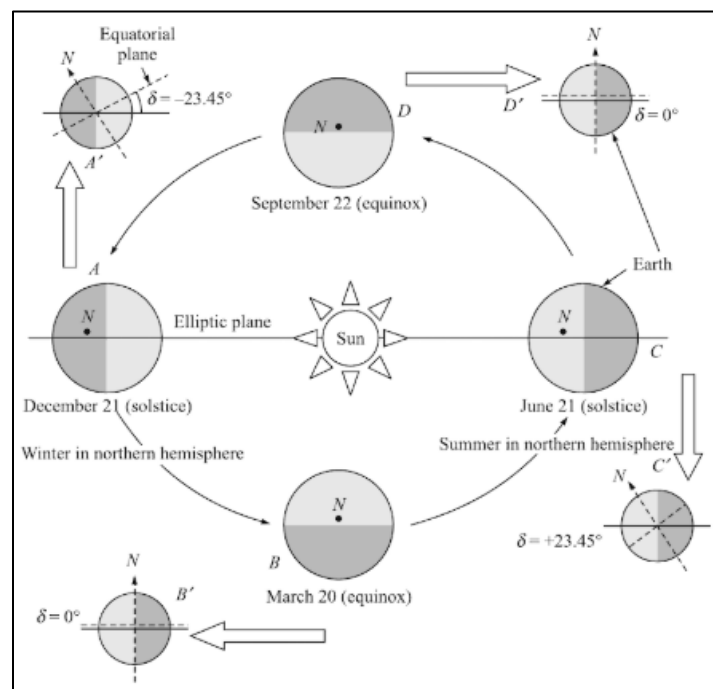

Figure 4. Position of the earth in relation to the sun [8]

2.3. Satellite Operation Mode

The nadir pointing mode on this satellite operation can affect the value of sun incidence angle in each time. Moreover, the sun incidence angle fluctuates to come into the surface of the satellite’s solar arrays due to satellite movement. Figure 5 illustrates the satellite position during operation in nadir pointing mode. There are three sides, Z-, X+, and X-, they will be evaluated by measuring the sun incidence angle from eq.1. Sun incidence angle is measured between the vector normal to the surface of the array and the sun line, as illustrated in figure 6.

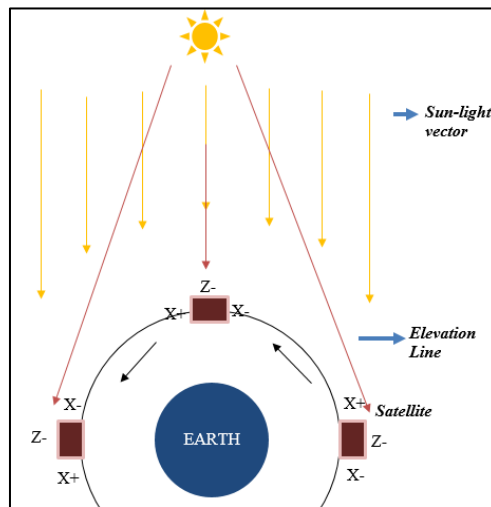

Figure 5. Illustration of satellite nadir-pointing mode

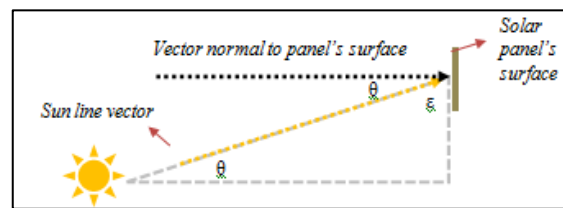

Figure 6. Sun Incidence angle, θ , and Satellite-to-sun elevation angle, ϵ

$$\cos \theta = \cos(90 - \epsilon) = \sin \epsilon \tag{1}$$

Where,

θ = Sun Incidence angle (deg), ϵ = Elevation Angle (deg) .

3. Power Produced Calculation [9]

Figure 3 shows the initial size of the solar arrays. The dimension of each arrays is 350 mm x 700 mm. The satellite's solar arrays using Gallium Arsenide (GaAs) type that has assumed has 30% of efficiency [8], then the other properties has been shown in table 1. To estimate power output, P_o , the required variable is the solar illumination intensity. Thus, the power output of the satellite is determined using the equation below:

$$P_o = 1367 \frac{W}{m^2} \times \eta = 1367 \frac{W}{m^2} \times 0.3 \tag{2}$$

Table 1. Solar array properties

Solar Panel Properties	
Inherent degradation, I_d *	0.770
Life degradation, L_d , for 5 yrs operation*	0.826
Efficiency, η **	0.300
Solar Illumination Intensity, Watt/m^2 *	1367
Power Output, P_o , Watt/m^2	410.1

* From reference [9]

** From reference [8]

Then, the further step is calculating amount of power that must be produced by solar arrays, P_{sa} .

$$P_{sa} = A_{sa} P_{EOL} \quad (3)$$

Power End of Life (PEOL) is the power of solar array when the satellite at the end of the designed satellite operational time (5 years). To calculate the PEOL, we must determine the power beginning of life (PBOL) and know how much the life degradation until the end of satellite operation. Eq 4 and 5 shows the equation to calculate PBOL and PEOL.

$$P_{BOL} = P_o I_d \cos\theta \quad (4)$$

$$P_{EOL} = P_o L_d \quad (5)$$

Table 2 shows the calculation result of P_{sa} . In equinox, the maximum P_{sa} is 63.90 Watt. Moreover, in this situation, the sun incidence angle has 0° when the sun vector come into the solar array surface perpendicularly. In other hand, the maximum P_{sa} is 58.63 Watt when the satellite in solstice. This value is not greater than the P_{sa} in equinox because of the declination of the sun that was mentioned.

Table 2. Power of solar array (P_{sa})

	Equinox	Solstice
Beginning of Life power per unit area, PBOL, Watt/m^2	315.78	289.70
End of Life power per unit area, PEOL, Watt/m^2	260.83	239.29
Area of solar array, A_{sa} , m^2	0.245	0.245
P_{sa} (available), Watt	63.90	58.63

The result above is according to the assumption that the sun vector is either perpendicular or at 23.45 degree in solstice to the solar array's surface. In the real operation, the satellite designed to orbit with nadir pointing mode. Therefore, the solar arrays will not produce maximum power continuously because of the consequence from the variation of satellite to sun elevation that affect the value of sun incidence angle.

4. Analysis

In the previous section, the power produced by solar array was determined. However, the maximum power is not continuously produced because of either the satellite nadir pointing mode or the deviations of sun position throughout the entire year.

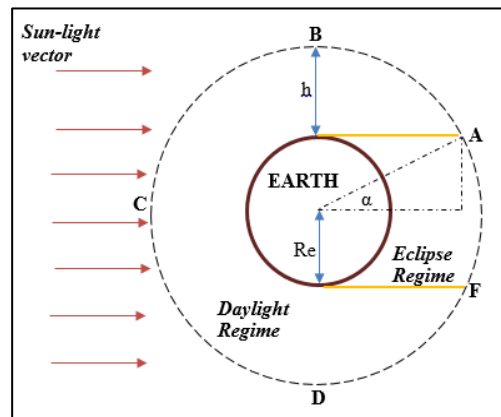

Figure 7. The satellite position in circular orbit illustration

Based on the configuration, the satellite with body mounted solar array would not fit to face the sun-light continuously with 0 degree of incidence angle. The Z- side has opportunity to get the sunlight in the half of orbit. In other side, the X- and the X+ just have shorter time than the Z- to catch the sunlight. Refer to figure 7, the Z- side will be illuminated from the B to the D. Then, the sunlight illuminates the X+ from the A to the C, and the X- from the C to the F.

4.1. Power Produced at The Z-

STK orbit simulation has been conducted for generating data of satellite-sun elevation during the specific time. To simplify the simulation, the data generated is produced by running the simulation at Wednesday, 20 March 2019 from 21:37:34 UTC to 22:32:19 UTC (equinox) and Friday, June 21 2019 from 0:45:16 UTC to 01:39:51 UTC (solstice). The data that has been generated consists of the elevation angle between the satellite and the sun each time. It has been shown in the graphic from figure 8.

The maximum elevation angle in the equinox regime is 89.98 degrees, and the solstice regime has 66.57 degrees of the maximum elevation angle. The gap between the maximum elevations angle in both regimes is approximately 23.5 deg. This number of angle also shows the evidence of the earth tilt angle changed during the equinox time to the solstice time. The elevation angle must be converted into the sun incidence angle by eq (1). Then, the results are multiplied by the power produced from table 1.

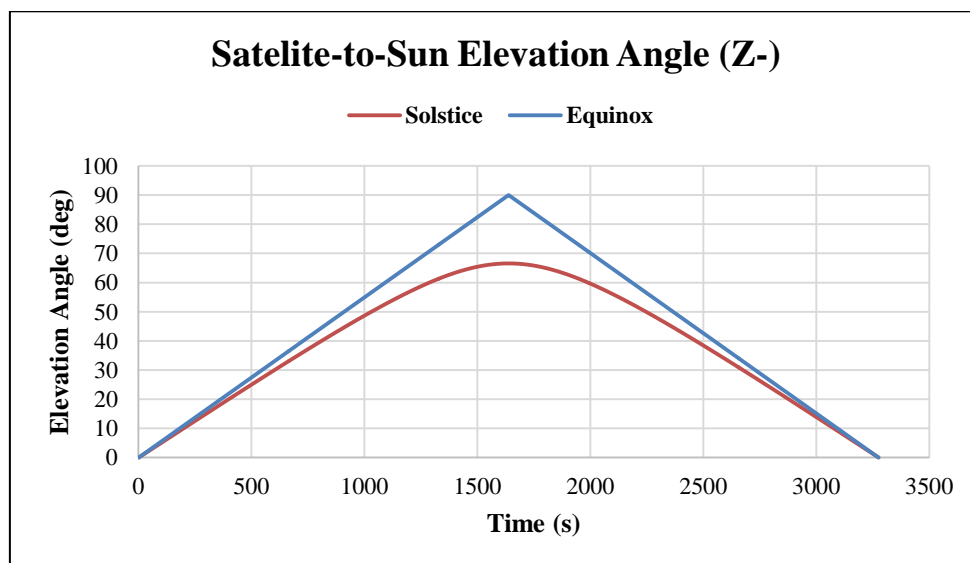

Figure 8. Elevation Angle between satellite and the Sun at the Z- side

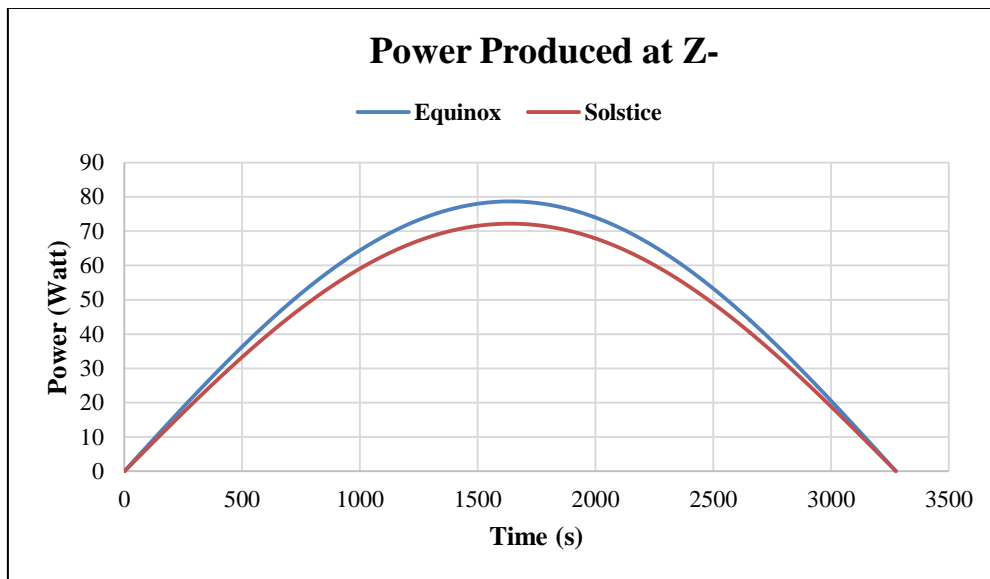

Figure 9. Power Produced at the Z- side

The graph from figure 9 shows the result of produced power in each time at the Z- side during the operation of the satellite. The average power produced is 50.09 Watt at the equinox, and 45.96 Watt at the solstice. Furthermore, the ratio of the power produced in the Z- with the power produced from the reference solar array in both regimes are 0.64 at the equinox and 0.58 at the solstice.

4.2. Power Produced at the X+ and the X-

Point A at figure 7 is a starting point for X+ position for getting solar illumination. Then, the elevation angle at the sun illumination starting point is:

$$\alpha = \sin^{-1} \left[\frac{6311 \text{ km}}{6371 \text{ km} + 1200 \text{ km}} \right] \cong 57.3 \text{ deg} \quad (6)$$

Based on the calculation above, when in equinox, the X+ starts to be illuminated when its side has satellite to sun elevation angle at 57.3 deg. The satellite in the X+ side, this angle is a starting point, and the ending point for receiving the sunlight. The angle when the satellite in the solstice is the angle in the solstice graph that has same time sample with the 57.3 degrees in equinox. So, the graph of the elevation angle is shown in figure 10, and the power produced is shown in figure 11.

The average power produced is 35.21 Watt at the equinox, and 32.32 Watt at the solstice. Furthermore, the ratio of the power produced in the X- and X+ with the power produced from the reference solar array in both regimes are 0.45 at the equinox and 0.41 at the solstice.

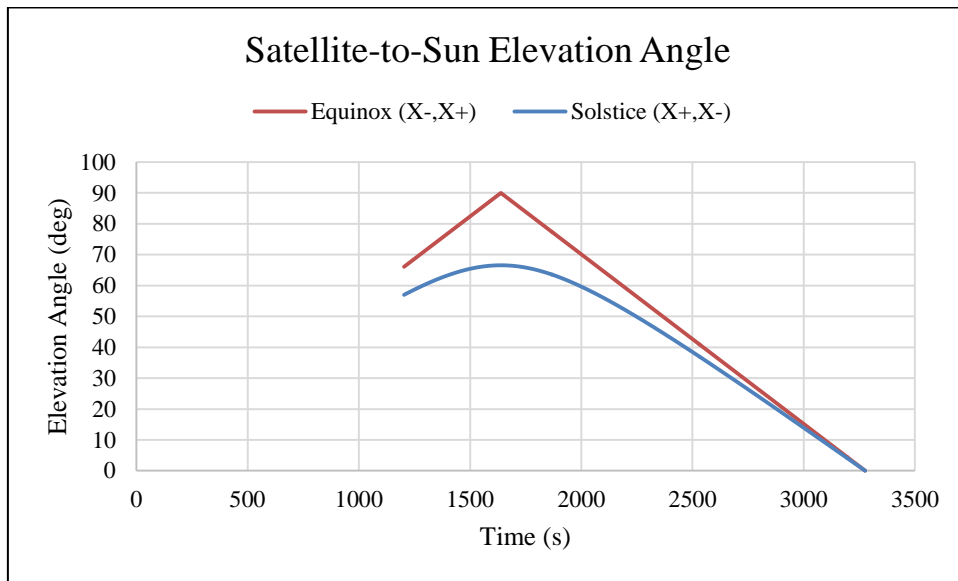

Figure 10. Elevation Angle between satellite and the Sun in the X+,X- side

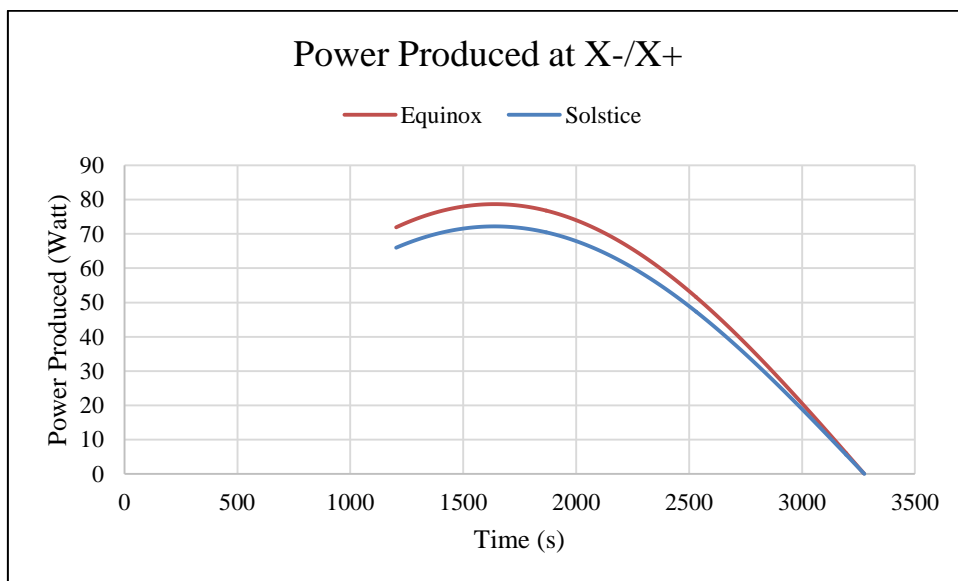

Figure 11. Power Produced in the X+,X- side

Table 3 shows the recap of the power produced result in each side.

Table 3 Resume of Analysis

	Z-		X+, X-	
	Equinox	Solstice	Equinox	Solstice
Max Power(Watt)	63.90	58.63	63.90	58.63
Max El (deg)	89.98	66.57	89.98	66.57
Power Avg (Watt)	40.68	37.32	28.59	24.08
Ratio	0.64	0.58	0.45	0.41

5. Conclusion

Sun position is a significant aspect for determining the power produced of the solar array. The difference in sun position can make different result. There are two sun positions, equinox, and solstice. In other hands, the nadir pointing mode in the satellite operation will affect the sun incidence angle that makes the cosine loss to power produced because the solar vector is not always perpendicular to the solar array's surface.

From the calculation, the maximum power produced in equinox is 63.90 Watt and 58.63 Watt in solstice. Then, in the Z- side of satellite produces the power, on average, as much as 40.68 Watt in equinox, and 37.32 Watt in solstice. Then, the X- and the X+, the average power produced is 28.59 Watt in equinox, and 24.08 Watt in solstice. Based on the result, the ratio of power produced could be determined by divide the average power produced with maximum power in each time. In the Z- side, the power produced ratio in equinox and solstice are 0.64 and 0.58. Then, the ratio in the X- and the X+ are 0.45 and 0.41.

In further actions, the result of the analysis can be used as an initial calculation for determining the power budget. This result work as a constraint to future research about solar array design.

6. Reference

- [1] Chad A, Chris B and Correntin G 2014 *Nano/Micro-Satellite Misions for Earth Observation and Remote Sensing* (UK: Satellite Applications Catapult Ltd) p 1
- [2] Shaded A, Paul G, Joel P and Kimberly K 2000 *Universal Small Payload Interface-An Assesment of US Piggyback Launch Capability* (USA: 14th Annual AIAA/USU Conf on Small Satellites) p 5
- [3] Gerard M and Jean J R 1991 *Low Earth Orbit Satellite Systems For Communications* (London: John Wiley & Sons, Ltd) p 210
- [4] Robertus H T, Wahyudi H, Ayom W, Mohammad M, and Udo R 2004 *Lapan-Tubsat: Micro-satellite Platform for Surveillance & Remote Sensing* (Bogor: LAPAN) p 5
- [5] Eun-Jung K, Eun-Sup S and Hae-Dong K 2017 Development of the power simulation tool for energy balance analysis of nanosatellites *Journal of Astronomy and Space Sciences* **34** pp 225-235
- [6] NASA 2015 *Small Spacecraft Technology State of the Art* (California: Ames Research Center) p 17
- [7] Robertus H T and Wahyudi H 2007 *Lapan Tubsat: From Concept to Early Operation* (Bogor: LAPAN) p 47
- [8] Chetan S S 2015 *Solar Photovoltaics Fundamental, Technologies and Applications 3rd edition* (India: PHI Learning Private Limited) p163
- [9] Wiley J L 2005 *Space Mission Analysis and Design 3rd edition* (The Netherland: Kluwer Academic Publisher) pp 407-427