



MILIK BIDANG PERPUSTAKAAN
PUSDIKLAT
BPP TEKNOLOGI

FINAL REPORT
STACK EMISSION TESTING PROGRAMS,
WORK PLACE AND AMBIENT AIR MONITORING
AT PT TAMBANG TIMAH, Tbk.
BALAI KARYA SUNGAILIAT
BANGKA, SOUTH SUMATERA

NO: 155/LAP.JATEK/LSDE/BPPT/VIII/2000

Prepared by:
Dr. Kardono
Dipl.-Ing Anky Padmadinata
Ir. Cahyadi, M.Kom
Ir. Muksin Saleh

Mengetahui :
Pusat Audit Teknologi BPPT
Kepala,
[Signature]
Dr. Ir. Adi Saptari, MSc
NIP. 680001434



Approved by:
Head of Energy Technology Assessment Division

[Signature]
Dr. Herman Agustiawan
NIP: 680001345

PERPUSTAKAAN	
No. Induk	: 1448/H/04
Klasifikasi	: JL 97.04.1448
Subjek	:
Harga / Asal	:
Pemb. / Had / Tk	:
Katalog	:
Di	: 04-10-04

ENERGY TECHNOLOGY LABORATORY
Agency for the Assessment and Application of Technology
PUSPIPTEK - SERPONG
☎ (62) (21) 7560562 EXT. 1157, 1180 or 1163
FAX: (62) (21) 7560904

EXECUTIVE SUMMARY

This report summarizes air pollution monitoring program of workplace and ambient air quality monitoring as well as stack emission at PT. Tambang Timah Tbk. - Balai Karya, Sungailiat, Bangka, South Sumatera. The number of sampling work was 2 (two) workplace environments, one outside ambient air and 3 (three) stacks. The targeted components measured at workplace environment and outside ambient air of *Komplek POLMAN*, a community settlement and *Balai Karya Cor (BK Cor)* were dust, SO₂, NO_x, CO. An additional measurement of formaldehyde (CH₂O) was done in *BK Cor*. At *BK Las*, the components measured at stack number 1 and 2 were particulate, SO₂, NO_x and CO.

Energy Technology Laboratory (LSDE) as a consultant through contract agreement with PT. Tambang Timah conducted the tests for ambient, workplace air quality monitoring and stack emission tests from June 20 to July 3, 2000.

The results of the tests demonstrated that:

- Total Suspended Particulate (TSP) measured at ambient air of *komplek POLMAN* and community settlement were 134 µg/Nm³ and 121 µg/Nm³ which were less than a given standard (230 µg/Nm³) as stipulated in Government Regulation PP No. 41. /1999. Similarly, Total Suspended Particulate (TSP) measured at workplace of *Balai Karya Cor* and *Balai Karya Las* were 5520 µg/Nm³ and 541 µg/Nm³ that were below the standard value (10,000 µg/m³) as depicted in SE-02/MENTRANS-KOP/1978.
- The concentrations of gaseous pollutants of SO₂, NO_x, NO₂ and CO measured at ambient air of *komplek POLMAN* were 27.22 µg/Nm³, 19.02 µg/Nm³, 5.63 µg/Nm³ and 1942 µg/Nm³, respectively. Similarly, those measured at community settlement were 26.98 µg/Nm³, 11.50 µg/Nm³, 5.54 µg/Nm³ and 2432 µg/Nm³, respectively. These values were all below the standard ambient air quality (365 µg/Nm³ for SO₂ in 24 hours, 150 µg/Nm³ for NO₂ in 24 hours and 10,000 µg/Nm³ for CO in 24 hours) as depicted in PP No. 41/1999.
- The average concentrations of SO₂, NO_x, and NO₂ measured at workplace air of *Balai Karya Cor* were 33.61 µg/Nm³, 24.47 µg/Nm³, 5.91 µg/Nm³ and 551 µg/Nm³, respectively. Also, those detected at *Balai Karya Las* were 19.80 µg/Nm³, 21.14 µg/Nm³ and 6.34 µg/Nm³, respectively. These values were all well below the standard workplace air quality as stipulated in SE-02/MENTRANS-KOP/1978. The work place formaldehyde (CH₂O) concentration measured at *BK Cor* and *BK Las* were found to be 10.35 mg/Nm³ and 13.45 mg/Nm³
- Result summaries of stack emission tests of Particulate, SO₂ and NO_x at *Balai Karya Las* were all below the current emission standards as stipulated in the KEP-13/MENLH/3/1995 under Other Activities effective for the year 2000.

TABLE OF CONTENTS

	Page
EXECUTIVE SUMMARY.....	i
TABLE OF CONTENTS.....	ii
LIST OF TABLES AND LIST OF FIGURES.....	iii
1. OBJECTIVE.....	1
2. BRIEF DESCRIPTION OF FACILITIES.....	1
2.1 Description of Exhaust System.....	2
3. SAMPLING PROCEDURES.....	4
3.1. Ambient/Workplace air quality sampling.....	4
- Total Suspended Particulate.....	5
- Sulfur Dioxide.....	5
- Carbon Monoxide.....	5
- Nitrogen Oxides.....	5
- Formaldehyde.....	5
3.2. Stack emission sampling tests.....	7
- Particulate sampling.....	7
- Gaseous Emission.....	8
4. RESULTS SUMMARY AND DISCUSSIONS.....	9
5. REFERENCES.....	13
APPENDIX 1 Field Data Sheets	
APPENDIX 2 Measured and calculated data	
APPENDIX 3 Team Participants	

LIST OF TABLES

	Page
TABLE 2.1 TRAVERSE POINTS of <i>BALAI KARYA LAS STACK</i> (DISTANCE FROM THE INSIDE STACK WALL)	2
TABLE 3.1 SAMPLING AND ANALYTICAL PROTOCOLS FOR AMBIENT AIR MONITORING	4
TABLE 3.2 SELECTED INDONESIAN AIR QUALITY AND EMISSION STANDARDS	6
TABLE 3.5 ANALYZED GASES AND MEASURING RANGES	8
TABLE 4.1 RESULT SUMMARIES OF AMBIENT AND WORKPLACE TSP CONCENTRATIONS, PT TAMBANG TIMAH Tbk, BALAI KARYA SUNGAILIAT	9
TABLE 4.2 RESULT SUMMARIES OF AMBIENT AND WORKPLACE GASEOUS POLLUTANTS, PT TAMBANG TIMAH Tbk, BALAI KARYA SUNGAILIAT	10
TABLE 4.3 RESULT SUMMARY OF WORKPLACE FORMALDEHYDE at PT TAMBANG TIMAH Tbk, BALAI KARYA SUNGAILIAT	11
TABLE 4.4 SUMMARY OF PARTICULATE MEASUREMENTS	11
TABLE 4.5 THE AVERAGE STACK GAS EMISSION FOR SO ₂ , CO and NO _x at 1 atm. and 25°C	12

LIST OF FIGURES

	Page
FIGURE 2.2 STACK SAMPLING PORTS AND POINTS CONFIGURATION of <i>BALAI KARYA LAS</i>	3
FIGURE 3.3 PROCEDURES FOR PARTICULATE SAMPLING	7
FIGURE 3.4 PARTICULATE SAMPLING TRAIN	8

1 OBJECTIVE

The workplace and ambient air quality monitoring as well as the stack emission tests at PT. Tambang Timah, Tbk. *Balai Karya* Sungailiat, Bangka, South Sumatra were conducted from June 28, 2000 until July 3, 2000.

The primary objectives of the program were:

- to obtain air pollution data of total suspended particulate (TSP), Sulfur dioxide (SO₂), Nitrogen oxides (NO_x), Carbon monoxide (CO) at work place and at ambient air levels in *Komplek POLMAN*, community settlement, *Balai Karya Cor (BK Cor)* and *Balai Karya Las (BK Las)*, as well as an additional measurement of formaldehyde (CH₂O) in *BK Cor*;
- to conduct stack emissions tests from *Balai Karya Las* stack number 1 and 2., particularly particulate and gaseous emissions such as sulfur dioxide (SO₂), nitrogen oxides (NO_x), carbon monoxide (CO).

Additional references and related materials are presented in the appendices.

2 BRIEF DESCRIPTION OF FACILITIES

Balai Karya Sungailiat is a supporting facility owned by PT. TAMBANG TIMAH, Tbk. This facility consists of several divisions and three of them are *Balai Karya Las (BKL)*, *Balai Karya Cor (BKC)* and *Balai Karya Listrik (BKLis)*. In *BKLis* division, there is no measurement conducted.

BKL is a division where a welding work is conducted in order to maintain the PT. TAMBANG TIMAH facilities. In this division, grinding machines, lathe machines, an electrode heater oven, welding machines etc are provided.

In *BKC*, however, several furnaces for casting work are provided. There are two kinds of furnace: coke casting furnace and arc furnace. Coke Casting furnace is not utilized anymore. Therefore, there is no stack sampling in *BK Cor*.

2.1 Description of Exhaust System

Both *BK Las* stack number 1 and 2 are 10 meters high from the ID fan with an inside diameter of 0.49 m. Four sampling ports at elevation of 9 meters from the ID fan are provided (see Figure 2.1). The stack at the time of measurement had a temperature between 29 - 35 °C.

- Sampling Location of BKL Stack.

For aiding representative measurement of pollutant from a stationary source, a measurement site was carefully selected, and the cross-section of the stack is divided into a number of equal areas. A traverse point is then located within each of these equal areas (see table 2.2). This method is applicable to flowing gas streams in stacks. Figure 2.1 shows the stack sampling port and the cross-sectional layout and traverse points location in this sampling test.

TABLE 2.2 TRAVERSE POINTS of *Balai Karya Las* stack
(Distance from the inside stack wall)

TRAVERSE POINT	Distance from the inside stack wall (mm)
1	32
2	122.5
3	367.5
4	457.2

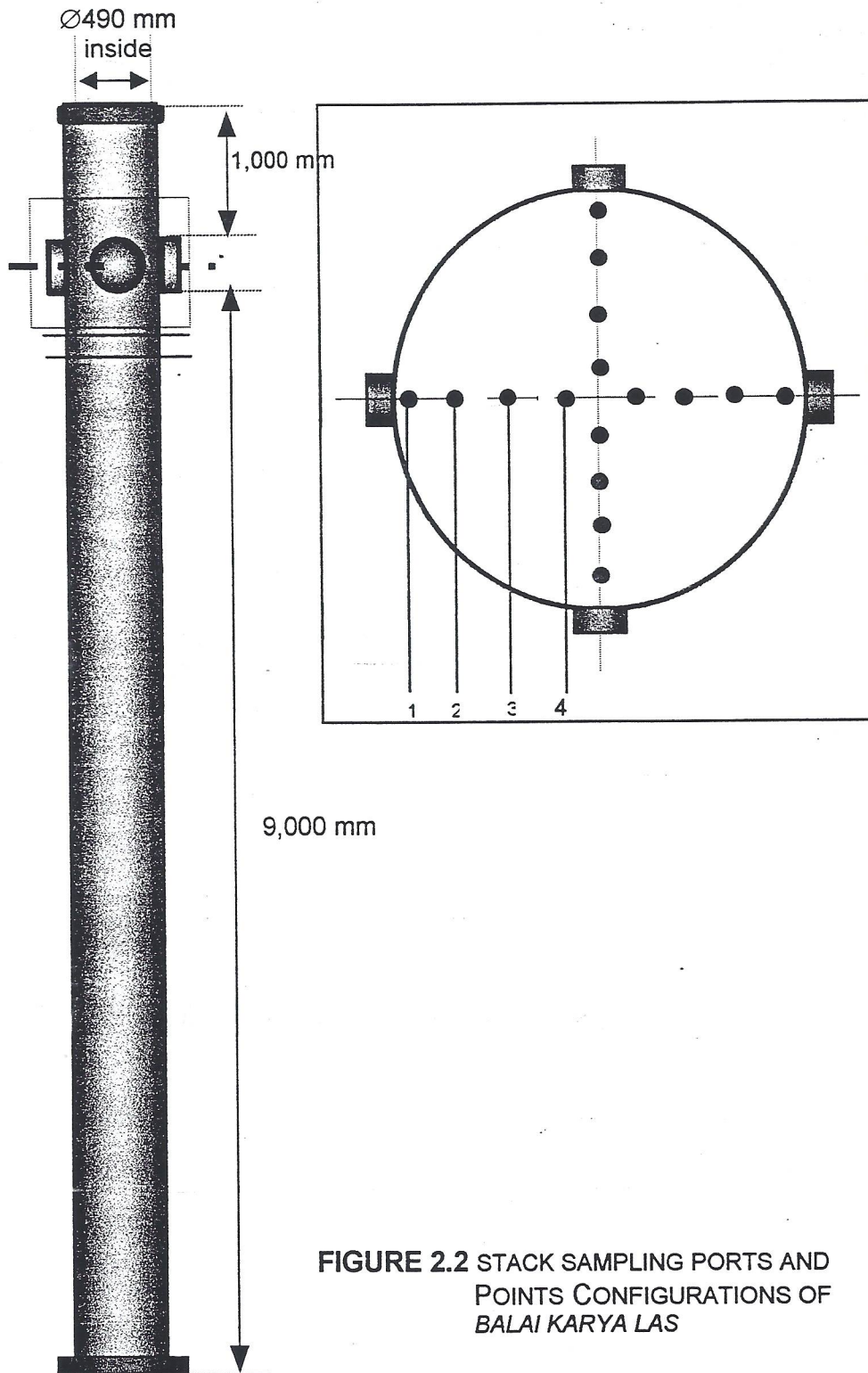

FIGURE 2.2 STACK SAMPLING PORTS AND POINTS CONFIGURATIONS OF BALAI KARYA LAS

3 SAMPLING PROCEDURES

3.1. Ambient/Workplace air quality sampling

Unlike procedure for stack sampling test, the procedure for an ambient air quality including work place monitoring has not officially been made available in Indonesia. Government of Indonesia (BAPEDAL) is preparing to make a such procedure that might be released in the near future. In this work however, most ambient air quality sampling methods used the draft prepared by BAPEDAL. Gaseous pollutants of ambient air were sampled using absorption method whereas TSP used a high volume sampling method.

Absorption in solvent, such as by bubbling the gas through a liquid, is a very common method for the collection of gaseous pollutants. Two characteristics of the absorbing device that increase collection efficiency are small bubble size and increased residence time.

The process of workplace and ambient air sampling begins with the vacuum withdrawal of a gas stream into an inlet probe at a constant flow rate. The ambient air pulled into the inlet probe is then collected on a glass scrubbing solution appropriate for a targeted gas. The concentration of the targeted gaseous pollutant collected on the scrubbing solution is then determined with an appropriate detection method in the laboratory. The following Table 3.1 gives information on sampling protocols and analyses commonly used in Indonesia.

TABLE 3.1 SAMPLING AND ANALYTICAL PROTOCOLS FOR AMBIENT AIR MONITORING

Sampling protocol	Parameter	Procedure/Analysis
BAPEDAL Draft or US-EPA method 40 CFR, Chapter I, Part 50, Appendix B	TSP	High Volume Sampling / Gravimetric method.
BAPEDAL Draft or WHO	NO ₂	Saltzman / Spectrophotometer
BAPEDAL Draft or WHO	CO	NDIR / NDIR Analyzer
BAPEDAL Draft or WHO	SO ₂	Pararosaniline method / Spectrophotometer
BAPEDAL Draft or WHO	HCOH	Aquadest solution/Gas Chromatography with Flusin T and He column

- **Total Suspended Particulate.** Method for determination of total suspended particulate (TSP) matter in the atmosphere uses a high volume method. This method provides a measurement of the mass concentration of TSP in ambient air in determining compliance with the national air quality standard for particulate matter. The measurement process is non-destructive and the size of the sample collected is usually adequate for subsequent chemical analysis, if needed. The only calibration necessary for particulate sampler is to its air flow meter. It is to establish trace ability of the field measurement to a primary standard via a flow rate transfer standard. The total amount of particulate collected is measured gravimetrically at the laboratory and calibration of the analytical balance used will be done as a part of laboratory work.
- **Sulfur Dioxide.** Method for determination of Sulfur Dioxide in the atmosphere uses a chemical method manually including bubbling air into the absorbent with a certain flow rate. Furthermore, the absorbent will turn chemically into a colored solutions, this color intensity is connected to the SO₂ concentration.
- **Carbon Monoxide.** Determination of Carbon Monoxide in the atmosphere uses Fourier Transform Infrared (FTIR). This method determines the carbon monoxide level in ambient air during the test execution. First of all, the air was pumped into the gas bulb container that had been already vacuumed until the container was fully filled by the air. Afterwards Fourier Transform Infrared analyzed the sample.
- **Nitrogen Oxides.** Determination of Nitrogen Oxides in the atmosphere uses a Spectrophotometer with Saltzman method. This method is intended for the determination of the nitrogen oxides level in ambient air during the test execution. The scope of the test includes the test method of the total nitrogen oxides level in the ambient air in the concentration range 0.005 – 5 ppm and the use of spectrophotometer, a laboratory instrument suitable for measuring the pink color at 550 nm. The absorbing reagent, N- (1-Naphthyl)-ethylenediamine dihydrochloride or NEDA solution, standard Sodium Nitrite solution, standard Sodium Nitrite stock solution and the calibration curve are required for the test preparation. The test procedures are as follow: pipett the absorbing reagent that contains the sample and put into a 10 ml graduated cylinder; dilute it with water to the mark; the absorbent that contains the sample will turn pink and then pour it into the cuvette of the spectrophotometer; read and note the inlet at the 550 nm wavelength.
- **Formaldehyde.** Sample analysis used for determination of formaldehyde uses Gas Chromatograph with Flusin T and He column as the carrier gas. In the field, some air was passed through 2 aquadest-contained impingers that were arranged serially. The flow rate of the air was 1 L/minutes. Aquadest was as formaldehyde absorbent. The sampling time was 2 hours.

The Government of Indonesia has released some standards of air qualities, consisting of ambient air quality, workplace air quality and emission standards. Government

Regulation, PP No. 41/1999, regulates ambient air quality standards whereas that for workplace is given by Ministry of Cooperatives and Transmigration, SE-02/MENTRANS-KOP/1978. For emission standard is released by Ministry of Environment through KEP-13/MENLH/3/1995. The following Table 3.2 shows the values of those standards for the measured pollutants at PT. TAMBANG TIMAH.

TABLE 3.2 SELECTED INDONESIAN AIR QUALITY AND EMISSION STANDARDS

Parameter	Standard in $\mu\text{g}/\text{Nm}^3$	Measurement duration	Analytical Method	Equipment
1 Ambient Standard*)				
- TSP	230 90	24 hours 1 year	Gravimetric	Hi-Vol
- CO	30,000 10,000	1 hour 24 hours	NDIR	NDIR Analyzer
- NO ₂	400 150 100	1 hour 24 hours 1 year	Saltzman	Spectropho meter
- SO ₂	900 365 60	1 hour 24 hours 1 year	Pararosaniline	Spectropho meter
2 Workplace air **)				
- TSP	10,000			
- CO	113,000			
- NO _x	46,250			
- SO ₂	1,300			
- Formaldehyde				
3 Emission Standard***)				
- TSP	350,000			
- NO _x	1,000,000			
- SO ₂	800,000			

*) PP NO. 41 / 1999

**) SE-02/MENTRANS-KOP/1978

***) KEP-13/MENLH/3/1995 (under: other activities) effective for the year 2000

3.2. Stack emission sampling tests

- **Particulate Sampling.** The process of particulate sampling begins with the vacuum withdrawal of a gas stream into a probe nozzle inside the stack such that the linear velocity of the gas entering the nozzle is the same as that in the stack. This representative sampling procedure is known as *isokinetic sampling*. The particulate pulled into the nozzle are then collected on a glass fiber filter maintained at a temperature of $120 \pm 12^\circ \text{C}$. The mass of the particulate collected on the filter is then determined gravimetrically in the laboratory.

Stack sampling provides information on the concentration of contaminant gases and particulate released to atmosphere from stationary sources. Although often used only to determine compliance with emission regulations, the stack test data can also provide information useful in evaluating control equipment design/collection efficiency and the economics associated with product recovery.

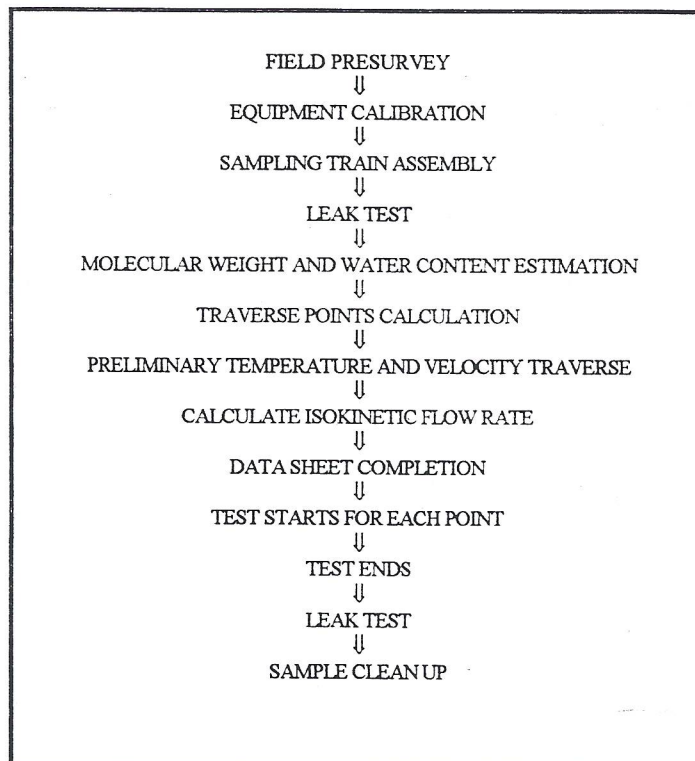

FIGURE 3.3. PROCEDURES FOR PARTICULATE SAMPLING

The sampling train selected to collect the particulate is a Graseby Andersen US-EPA Method 5 train as depicted in Figure 3.4 below.

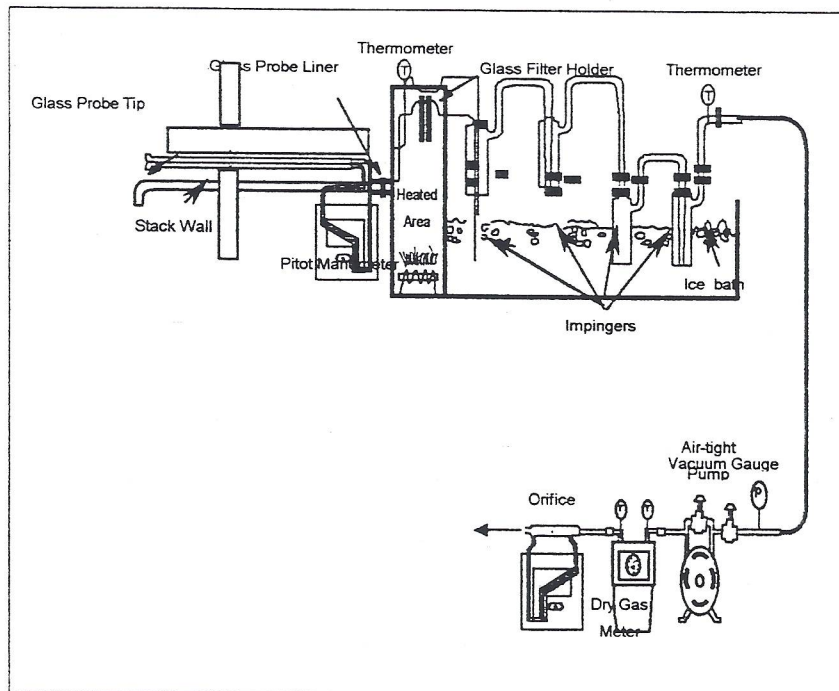

FIGURE 3.4 PARTICULATE SAMPLING TRAIN

- **Gaseous Sampling.** A COSA model 6000 CD Gas Analyzer was used to detect stack gases (CO, CO₂, NO_x, SO₂) through an electrochemical sensor. The measuring ranges of the analyzer differed from one gas to another, as shown in Table 3.5.

TABLE 3.5 ANALYZED GASES AND MEASURING RANGES

ANALYZED GASES	RANGE	ACCURACY	SENSITIVITY	SENSOR TYPE
CARBON MONOXIDE	0-8000 PPM	± 2.0 %	1.0 PPM	ELECTROCHEMICAL
CARBON DIOXIDE	0-25 %*	± 2.0 %	1.0 PPM	-
SULFUR DIOXIDE	0-4000 PPM	± 2.0 %	1.0 PPM	ELECTROCHEMICAL
NITRIC OXIDE	0-4000 PPM	± 2.0 %	1.0 PPM	ELECTROCHEMICAL
TEMPERATURE	0-2200 F	± 2.0 %	1.8 F	THERMOCOUPLE "K"

*CALCULATED VALUE

The analyzer detects the gas automatically whenever the probe is introduced into the gas stream. The results are stored in the analyzer's memory, and can be saved on diskette, displayed on a computer monitor, and/or printed out directly on site. The gaseous sampling equipment was assembled and checked prior to testing; it was calibrated with procedures recommended by COSA.

4 RESULTS SUMMARY AND DISCUSSIONS

4.1 Ambient and Workplace air monitoring

Particulate and gaseous pollutants. There were 3 (three) locations of ambient air and workplace to be detected for TSP and gaseous pollutants such as SO₂, CO and NO_x. Those were *komplek POLMAN*, community settlement and Balai Karya Cor. At these locations, total suspended particulate (TSP) matter was sampled in 24 hours sampling time. A summary of all TSP measurements is given in Table 4.1 below and detailed values are given in Appendix.

TABLE 4.1 RESULT SUMMARIES OF THE AMBIENT AND WORKPLACE TSP CONCENTRATIONS, PT TAMBANG TIMAH Tbk., BALAI KARYA SUNGAILIAT

No	Location	Time of Measurement	The Workplace TSP, $\mu\text{g}/\text{m}^3$	The Ambient TSP, $\mu\text{g}/\text{m}^3$
A	AMBIENT:			
1.	<u><i>Komplek POLMAN</i></u>	In the morning (1 hour) In the afternoon (1 hour) In the night (1 hour) 24 hours	-	134
2.	<u>Community settlement</u>	In the morning (1 hour) In the afternoon (1 hour) In the night (1 hour) 24 hours	-	121
B	WORK PLACE:			
3.	<u><i>Balai Karya Cor</i></u>	In the morning (1 hour) In the afternoon (1 hour) In the night (1 hour) 24 hours	5520	-
4.	<u><i>Balai Karya Las</i></u>	In the morning (1 hour) In the afternoon (1 hour) In the night (1 hour) 24 hours	541	-

Table 4.1 indicates that ambient TSP levels in *komplek POLMAN* and community settlement were $134 \mu\text{g}/\text{m}^3$ and $121 \mu\text{g}/\text{m}^3$, respectively and these values are below the ambient TSP standard of $230 \mu\text{g}/\text{m}^3$ as stipulated in Government

Regulation PP No. 41/1999. The workplace TSP levels in *BK Cor* and *BK Las* were $5520 \mu\text{g}/\text{m}^3$ and $541 \mu\text{g}/\text{m}^3$. These values are also well below the given standard ($10,000 \mu\text{g}/\text{m}^3$) as depicted in SE-02/MENTRANS-KOP/1978.

In these 3 (three) locations of ambient and workplace air, gaseous pollutants such as SO_2 , CO and NO_x were also detected. The following table 4.2 shows the values of ambient and workplace air quality monitoring data for the gaseous pollutants.

Table 4.2 indicates that the respective values of ambient SO_2 , NO_x , NO_2 and CO levels measured in *komplek POLMAN* were $27.22 \mu\text{g}/\text{m}^3$, $19.02 \mu\text{g}/\text{m}^3$, $5.63 \mu\text{g}/\text{m}^3$ and $1942 \mu\text{g}/\text{m}^3$. Those measured in community settlement were $26.98 \mu\text{g}/\text{m}^3$, $11.50 \mu\text{g}/\text{m}^3$, $5.54 \mu\text{g}/\text{m}^3$ and $2432 \mu\text{g}/\text{m}^3$, respectively. These values were all less than their standard values as stipulated in Government Regulation PP 41/1999.

Similarly, the respective average values of workplace SO_2 , NO_x , NO_2 and CO levels measured in *BK Cor* were $33.61 \mu\text{g}/\text{m}^3$, $24.47 \mu\text{g}/\text{m}^3$, $5.91 \mu\text{g}/\text{m}^3$ and $551 \mu\text{g}/\text{m}^3$. These values were all less than their standards as stipulated in SE-02/MENTRANS-KOP/1978 as the workplace air quality standard.

TABLE 4.2 RESULT SUMMARIES OF AMBIENT AND WORKPLACE GASEOUS POLLUTANTS, PT TAMBANG TIMAH Tbk., BALAI KARYA SUNGAILIAT

No.	LOCATION	Time of Measurement	$\mu\text{g}/\text{Nm}^3$			
			SO_2	NO_x	NO_2	CO
A	AMBIENT:					
1.	<u>Komplek POLMAN</u>	In the morning (1 hour)	42.84	35.06	9.35	1580
		In the afternoon (1 hour)	41.09	24.39	6.57	2690
		In the night (1 hour)	36.03	24.39	8.91	4290
		24 hours	27.22	19.02	5.63	1942
2.	<u>Community settlement</u>	In the morning (1 hour)	41.02	15.45	7.02	1240
		In the afternoon (1 hour)	48.12	18.79	8.93	4640
		In the night (1 hour)	29.76	16.44	8.46	4840
		24 hours	26.98	11.50	5.54	2432
B	WORK PLACE:					
3.	<u>Balai Karya Cor</u>	In the morning (1 hour)	65.65	35.06	12.15	870
		In the afternoon (1 hour)	42.05	44.17	6.54	100
		In the night (1 hour)	40.44	28.63	7.36	1460
		24 hours	33.61	24.47	5.91	551
4.	<u>Balai Karya Las</u>	In the morning (1 hour)	34.68	31.79	10.28	
		In the afternoon (1 hour)	28.04	35.17	9.81	
		12 hours	19.80	21.14	6.34	

4.2 Workplace Formaldehyde

Formaldehyde detection is conducted in *Balai Karya Cor* and *Balai Karya Las* workplace. The measurement results showed that formaldehyde concentration in *BK Cor* in the morning was 16.47 mg/Nm³, in the afternoon 15.39 mg/Nm³ and in the evening was only 13.77 mg/Nm³. Thus, the average measurement was 10.35 mg/Nm³ formaldehyde concentrations. In *BK Las* the highest value of formaldehyde was detected in the morning (i.e. 33.85 mg/Nm³) and the lowest was measured in the afternoon (i.e. 8.75 mg/Nm³). The average value of formaldehyde concentration detected in *BK Las* was 10.35 mg/Nm³.

TABLE 4.3 RESULT SUMMARIES OF WORKPLACE FORMALDEHYDE AT PT TAMBANG TIMAH Tbk., BALAI KARYA SUNGAILIAT

No	Location	Time of Measurement	Formaldehyde, mg/Nm ³
1.	WORK PLACE: <i>Balai Karya Cor</i>	In the morning (1 hour) In the afternoon (1 hour) In the night (1 hour) 24 hours	16.47 15.39 13.77 10.35
2.	<i>Balai Karya Las</i>	In the morning (1 hour) In the afternoon (1 hour) 24 hours	33.85 8.75 13.45

4.3 Stack emissions

Particulate. A summary of the particulate measurement is given in Table 4.4 below and detailed values are given in the Appendix.

TABLE 4.4. SUMMARY OF PARTICULATE MEASUREMENTS

Location	Average Particulate Concentration in mg/m ³
<i>Balai Karya Las Stack number 1</i>	85.53
<i>Balai Karya Las Stack number 2</i>	122.74

Table 4.4 indicates that the average particulate concentrations measured at BK Las stack number 1 and 2 were 85.53 mg/m^3 and 122.74 mg/m^3 ; respectively. It was therefore far below the standard of 350 mg/m^3 as stipulated in KEP-13/MENLH/3/1995 under Other Activities effective for the year 2000.

Gaseous pollutants. The emission tests for gaseous pollutants at BK Las stack number 1 and 2 included SO_2 , CO and NO_x measurement. Based on the current emission standards for SO_2 and NO_x as stipulated in the KEP-13/MENLH/3/1995 under Other Activities effective for the year 2000, the average SO_2 stack emissions at BK Las stack number 1 that was 8 mg/m^3 and at BK Las stack number 2 were all below the standard.

Furthermore, the average NO_x emissions at BK Las stack number 1 and 2 were 1.3 mg/m^3 and below detection limit; respectively. These all values were also well below the current standard, which are 800 mg/m^3 for SO_2 stack emissions and $1,000 \text{ mg/m}^3$ for NO_x . Result summaries of the stack gas emission tests are shown in Table 4.5 and the detailed measurements are given in Appendix.

TABLE 4.5. THE AVERAGE STACK GAS EMISSION FOR SO_2 , CO and NO_x at 1 atm. and 25°C

Location/Stack	Date	SO_2 , mg/m^3	NO_x , mg/m^3
Balai Karya Las stack number 1	28/06/2000	8.0	1.3
Balai Karya Las stack number 2	28/06/2000	bdl*	bdl

bdl* = below detection limit