

See discussions, stats, and author profiles for this publication at: <https://www.researchgate.net/publication/341972067>

# Determination of robust weights hidden layers on backpropagation algorithm to analyze coefficient drag high-speed train

Article in *Journal of Physics Conference Series* · June 2020

DOI: 10.1088/1742-6596/1511/1/012074

CITATIONS

0

READS

12

4 authors, including:



**Suksmono Adityo**

Statistics Indonesia

4 PUBLICATIONS 2 CITATIONS

[SEE PROFILE](#)



**Hendrato S.T.**

Badan Pengkajian dan Penerapan Teknologi

3 PUBLICATIONS 0 CITATIONS

[SEE PROFILE](#)



**Ansori Irfan**

Badan Pengkajian dan Penerapan Teknologi

1 PUBLICATION 0 CITATIONS

[SEE PROFILE](#)

Some of the authors of this publication are also working on these related projects:



Wind tunnel flutter test of half wing N219 aircraft model [View project](#)

PAPER • OPEN ACCESS

## Determination of robust weights hidden layers on backpropagation algorithm to analyze coefficient drag high-speed train

To cite this article: Suksmono Adityo *et al* 2020 *J. Phys.: Conf. Ser.* **1511** 012074

View the [article online](#) for updates and enhancements.



**IOP | ebooks™**

Bringing together innovative digital publishing with leading authors from the global scientific community.

Start exploring the collection—download the first chapter of every title for free.

# Determination of robust weights hidden layers on backpropagation algorithm to analyze coefficient drag high-speed train

**Adityo Suksmono, Hendrato, Sucipto, Irfan Ansori**

Center of Technology for System and Infrastructure of Transportation, Agency for The Assessment and Application of Technology, Serpong, Banten, Indonesia

**Abstract.** In this research, we developed a method using backpropagation to analyze the coefficient drag of high-speed trains. Analyzing coefficient drag using a backpropagation algorithm has more benefits, especially in cost and time, than using computational fluid dynamics. Computational fluid dynamics need sophisticated software and hardware. It needs much time to get a convergent result as well. We used 2D coordinates longitudinal profile nose of the high-speed train as an input of the backpropagation algorithm. The weights between hidden layers and input layers and between hidden layers and output layers, respectively, were modeled as matrices that were formed from the iteration process. The coefficient drag differences, between backpropagation algorithm and computational fluid dynamics analysis, from each iteration, were used as a correction factor to form robust weights hidden layers matrices. The results of this research showed that training in the backpropagation algorithm can obtain robust weights of hidden layers that have been known from Mean Sum Square Error in an exercise that is small enough. Because of the limited time to finish this research, we only trained and exercised nine models instead of a thousand models. Robustness weights that are resulted in this research are expected to contribute to accelerating a coefficient drag prediction of high-speed train accurately. To improve this proposed method, 3D coordinates of the nose's surface of high-speed trains and many more 3D models are needed.

## 1. Introduction

Reducing energy consumption at a high-speed train to reduce its cost is the main target for the high-speed train design phase recently. To achieve this, it must be started with proper design. Design processes involve CFD analysis, which then it will be validated in wind tunnel testing. It is an iterative process because based on wind tunnel testing it will give feedback to updated design to fulfill design requirements. Thus design process needs more budget and time. For that reason, we need sophisticated software to analyze accurately because of a lack of accusation in phase design which is validated using wind tunnel testing, which is more cost and time to update the initial design.

To make a faster and cheaper phase design, in this research, by using the Backpropagation algorithm, we developed robust weights between input layers and hidden layers and weights between hidden layers and output layers. Ideally, this process needs more models as a sample but because of many constraints, we just used just nine models. This research involved three main subjects, which are a design that needs a mathematical formula to describe the profile and is generated to become 3D high-speed train models, Computational fluid dynamics to compute coefficient drag model, and the last Artificial Neural Network using the Backpropagation algorithm. The backpropagation algorithm is



prepared to substitute Computational Fluids dynamics that need high spec hardware, software, and more time to the simulation process.

**Table 1.** Specification Hardware and Software.

	<i>Design Process</i>	<i>aerodynamics Analysis</i>	<i>Artificial Neural Network Analysis</i>
<b>RAM</b>	6 Gb	6 GB	6 GB
<b>Processor</b>	Core i5	Core i7	Core i5
<b>Capacity</b>	1 TB	1 TB	1 TB
<b>Software</b>	Inventor	OpenFoam	Matlab R2014a
<b>OS</b>	Windows 7	Ubuntu	Windows 7

## 2. Theoretical Background

### 2.1. Modeling Longitudinal High-Speed Train Nose Profile

In this research, we used two main mathematical formulas to model a longitudinal nose of a high-speed train model. The formulas are ellipsoid formula and Hicks-Henne Function. The formulas are shown respectively in equation (1) and (2).

$$\frac{x^2}{a^2} + \frac{y^2}{b^2} = 1 \quad (1)$$

Where

a=length of the semi-major axis

b=length of the semi-minor axis

x=abscis of coordinates of any point on the ellipse

y= ordinate of coordinates of any point on the ellipse

$$Y = Y_{base} + \sum_{i=1}^N W_i f_i \quad (2)$$

Where  $Y_{base}$  is the baseline function.  $F_i$  and  $W_i$  stand for the Hick-Henne shape function and the weights factor, respectively. The Hick-Henne shape function  $F_i$  is described in the following Equations [1].

$$\begin{aligned} F_1 &= \frac{x(1-x)}{e^{20x}} & 0 < W_1 < 0.12 \\ F_2 &= \sin(\pi x^{0.25})^3 & 0.03 < W_2 < 0.15 \\ F_3 &= \sin(\pi x^{0.5})^3 & 0.01 < W_3 < 0.1 \\ F_4 &= \sin(\pi x^{0.8})^3 - 0.05 & 0.05 < W_4 < 0.05 \\ F_5 &= \sin(\pi x^{1.357})^3 - 0.06 & 0.06 < W_5 < 0.04 \\ F_6 &= \sin(\pi x^3)^3 - 0.06 & 0.06 < W_6 < 0.04 \end{aligned} \quad (3)$$

## 2.2. Computational Fluids Dynamics Analysis

Navier-Stokes equations are used to analyze aerodynamics phenomena like drag force, lift force, aerodynamics moments, etc. There are no analytic solutions to solve the equations, so it is needed Computational Fluids Dynamics to solve it numerically. Navier stokes equations consist of many equations that describe conservation in continuity, momentum, and energy. Simplifying Navier-Stokes equations in the general form is shown in equations (4) [2].

$$\frac{\partial(\rho\Phi)}{\partial t} + \frac{\partial}{\partial x_i} \left( \rho U_i \Phi - \Gamma_\Phi \frac{\partial \Phi}{\partial x_i} \right) = q_\Phi \quad (4)$$

In computational fluids dynamics, the Navier-Stokes equations are discretized so it can be solved numerically using grid concepts.

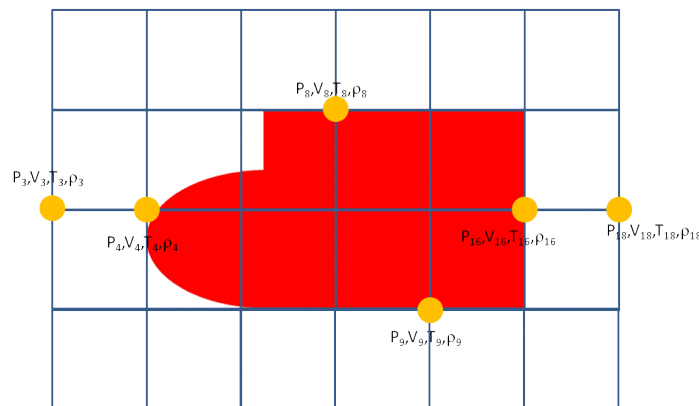

**Figure 1.** Description of grid concepts in CFD simulations.

## 2.3. Backpropagation Algorithm

Backpropagation algorithms are a family of methods used to efficiently train artificial neural networks (ANNs) following a gradient-based optimization algorithm that exploits the chain rule. The main feature of backpropagation is its iterative, recursive and efficient method for calculating the weights' update to improve the network until it can perform the task for which it is being trained.

In the human being, neural networks are activation function to process input signal which can be modeled mathematically as Sigmoid bipolar activation and Sigmoid multipolar equation. In this research we used Sigmoid bipolar because it is more accurate, that is shown in equation (5) [3]

$$f(x) = \frac{1 - e^{-x}}{1 + e^{-x}} \quad (5)$$

Ending iteration process in Backpropagation algorithms is when the mean sum squared error is less than tolerance value. Mean sum squared error is a parameter that shows the sum of the total deviation between output and target in each iteration. Mean sum squared error is shown in equation (6)[4]

$$MSSE = \frac{1}{N} \sum_{i=1}^N [Target - Output]^2 \quad (6)$$

Where N is several data

## 3. Methods

Methods have been used in this research shown in figure 2.

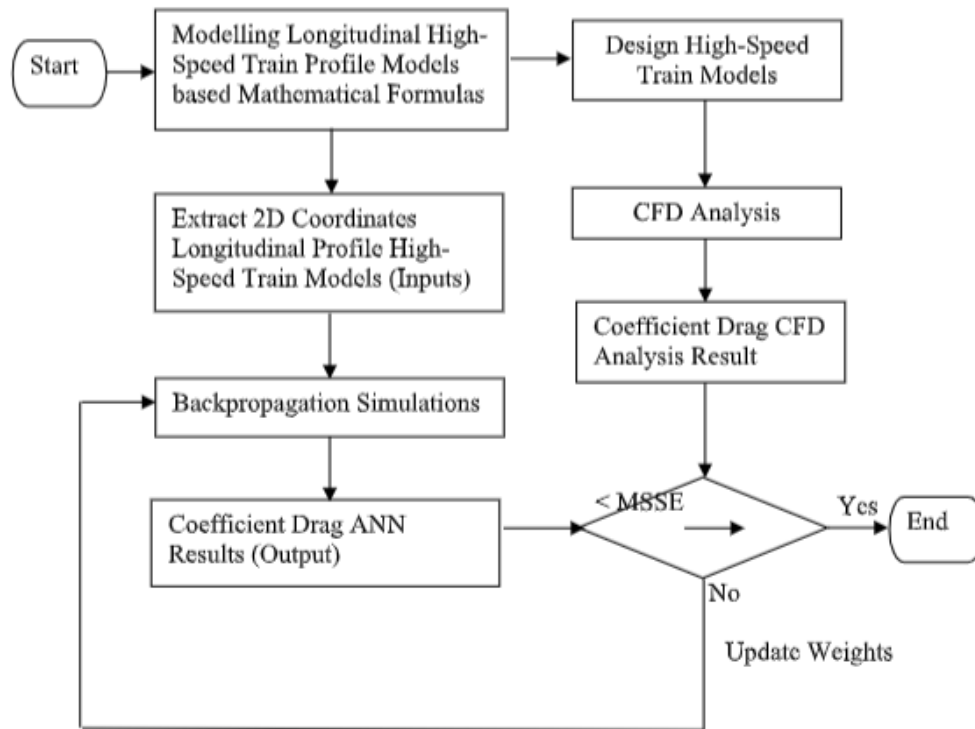

**Figure 2.** Flowchart research

### 3.1. Design Model

The design of a high-speed train model was initialized from longitudinal nose high-speed train profile models which consist of many coordinates that were derived from mathematical formulas. Three mathematical formulas generate non-dimensional geometries. In each non-dimensional geometries was variated in length, they are 3000 m, 5000m, and 7000 m. Based on 2D longitudinal nose high-speed train models, the 3D models were drawn using inventor software. The head size of the high-speed train model is 23 m x 3 m x 3 m (length x wide x height). However, the size of models are completely similar but it can be variated into the different length of the nose and mathematical model that construct nose.

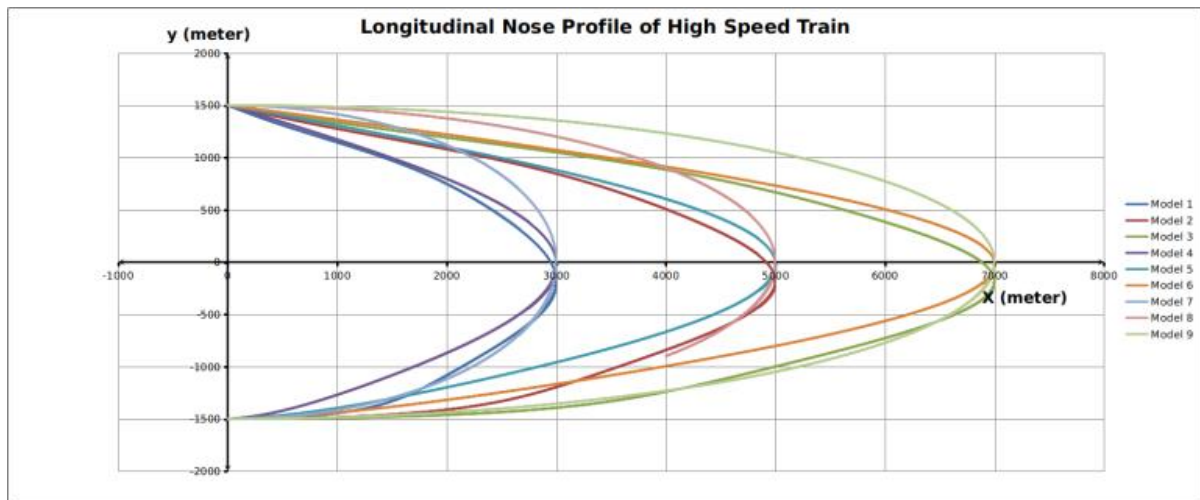

**Figure 3.** Longitudinal Nose Profile

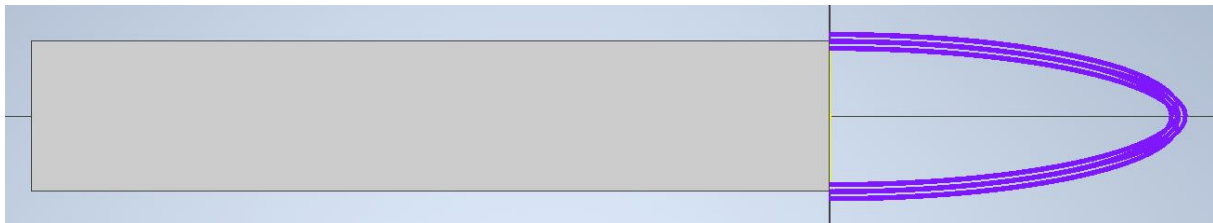

**Figure 4.** 2D Nose Modeling

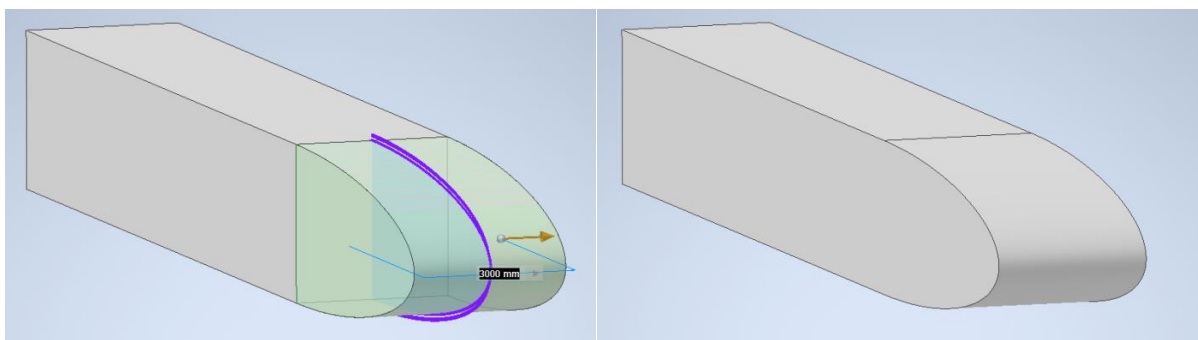

**Figure 5.** 3D Nose Modeling

### 3.2. Computational Fluids Dynamics Analysis

Computational fluids analysis was used to compute coefficient drag in each model. In aerodynamics, the parameter gives information about drag. Drag is caused by relative velocity between moving objects and air molecules. When air molecules hit surface objects, it causes pressure drag and friction between air molecule and the object's skin, that cause friction drag. The sum of two types of drag is a total drag. Drag that is divided by multiplying results kinetic energy and surface is a coefficient drag. So it could get two coefficient drags, that is coefficient drag pressure and coefficient drag friction. In this research, coefficient drag was computed by computational fluids dynamics and simulated using OpenFoam software.

One of the most important efforts to minimizing coefficient drag is by designing longitudinal profile objects. In this research, we used three mathematical formulas to construct a high-speed train

nose in which each formula is used to construct the noise model which its length respectively are 3000 m, 5000 m, and 7000 m.

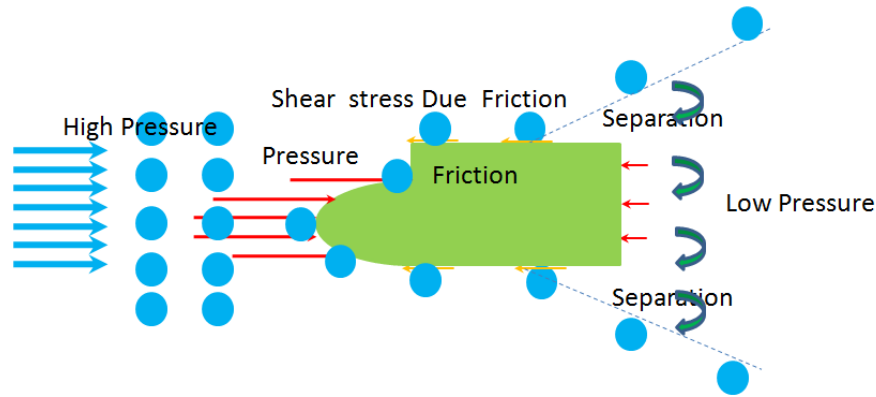

**Figure 6.** Description of drag due to pressure and friction

### 3.3. Backpropagation Analysis





Backpropagation analysis is one of the artificial neural network methods that adopt a human being thinking process to find the pattern to identify the object. The objective of this research is to find relation patterns between high-speed train coefficient drag and longitudinal two-dimensional coordinates nose of high-speed train model. The pattern can be found using robust weights that connect between input layers and hidden layers, and between hidden layers and output layers. Why must the weight be robust? Because the backpropagation algorithm will substitute computational fluids dynamics analysis to compute coefficient drag high-speed train. Ideally, backpropagation analysis uses huge amounts of models but because of many constraints, we only used nine models. Next time, the research will be planned using huge amount models and will be up to date that it will use three-dimensional coordinates as input to compute high-speed train coefficient drag. The source code of the Backpropagation algorithm is made by Matlab software and all computation involves matrice operation.

## 4. Drawing Model and Computational Simulation

Drawing 3D head of high-speed train models was based on its longitudinal nose profiles. The longitudinal nose profiles were generated from 2D coordinates that were extracted from mathematical formulas which are variated in length in each formula. First, we determined constant value in each formula that is shown in part 2.1 before. Based on the formula, we can plot its contour. Then the 2D contour is generated to become the 3D surface of the head of the high-speed train. The contour is very simple which is on the lateral side just follow a longitudinal nose profile. Actually, the nose of the high-speed train is more complex. The longitudinal nose profiles, its formula, and the value of constant are shown in Table 2.

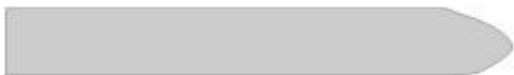
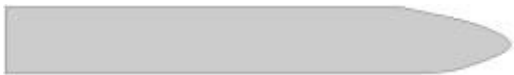

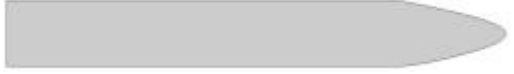
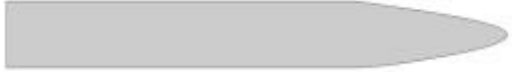
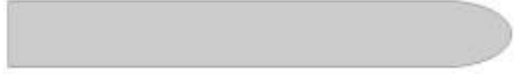
**Table 2.** Mathematical Formulas Derive Longitudinal Nose of High-Speed Train Models

Model	Mathematical Formula	Constant Value	Length of the nose(m)
Model 1 	$Y = Y_{base} + \sum_{i=1}^N W_i f_i$	$f_2 = 0.1$	3
Model 2 	$Y = Y_{base} + \sum_{i=1}^N W_i f_i$	$f_2 = 0.1$	5
Model 3 	$Y = Y_{base} + \sum_{i=1}^N W_i f_i$	$f_2 = 0.1$	7
Model 4 	$Y = Y_{base} + \sum_{i=1}^N W_i f_i$	$f_2 = 0.4$ and $f_6 = 0.1$	3
Model 5 	$Y = Y_{base} + \sum_{i=1}^N W_i f_i$	$f_2 = 0.4$ and $f_6 = 0.1$	5
Model 6 	$Y = Y_{base} + \sum_{i=1}^N W_i f_i$	$f_2 = 0.4$ and $f_6 = 0.1$	7
Model 7 	$\frac{x^2}{a^2} + \frac{y^2}{b^2} = 1$	$a = 3000$ $b = 1500$	3
Model 8 	$\frac{x^2}{a^2} + \frac{y^2}{b^2} = 1$	$a = 5000$ $b = 1500$	5
Model 9 	$\frac{x^2}{a^2} + \frac{y^2}{b^2} = 1$	$a = 7000$ $b = 1500$	7

The nine models of the head of the high-speed train, which were converted to the obj file format, were inputted to aerodynamics analysis using OpenFoam. Before the simulation was started, it must be set up many aerodynamics parameters that are shown in table 3. The output of aerodynamics analysis is the coefficient drag of each model that becomes the target of Backpropagation simulation in the training phase to get robust weights.

**Table 3.** Aerodynamics Parameters

Parameter	Value
Wind Speed	44.44 m/s
Frontal Area	9 m <sup>2</sup>
Air Density	1.225 kg/m <sup>3</sup>
Viscosity	1.789 x 10 <sup>-5</sup> Kg/m/s
Total Pressure	1.01 x 10 <sup>5</sup> Pa

Coefficient drag values are fluctuating before they reach convergent values. We took a coefficient drag from each model as the target of backpropagation simulation when it has been convergent.

**Table 4.** Architecture ANN Backpropagation

Characteristics	Specification
Architecture	1 hidden layer
Input neuron	4000
Hidden Neuron	50
Input neuron	1
Activation Function	Sigmoid
Initialization weights	Random
MSSE	Less than 10 <sup>-8</sup>
Maximum Epoch	10000

To obtain robust weights between input layers and hidden layers and between hidden layers and output layers using Backpropagation simulation, it must determine many parameters, which are shown in table 4, that it is more like trial and error process.

## 5. Results and Analysis

In backpropagation analysis in this research using 4 configurations that are be varied in composition number model which include training or exercise respectively. The robustness of weights each configuration is shown in parameter MSSE. The results are shown in Table 5. Based on table 5 it can be concluded that the more models simulated in training the more robust weights between input layers and hidden layers and between hidden layers and output layers. It shows that the more models were included in training the smaller MSSE in exercise. We hope the research will be continued using a lot of models and to accommodate the complex shape of the head of the high-speed train and many aerodynamics parameters, the profile of the nose must be in 3D coordinates.

**Table 5.** Configuration in Backpropagation Analysis

Model	Training	Excercise	MSSE Excercise
Configuration I	9 models	9 models	6.73 x 10 <sup>-9</sup>
Configuration II	8 models	1 model	8.92 x 10 <sup>-7</sup>
Configuration III	7 models	2 models	8.92 x 10 <sup>-5</sup>
Configuration IV	6 models	3 models	9.63 x 10 <sup>-5</sup>

Because we only used nine models in this simulation, the time to get the convergent result was very fast. It only took 10.000 epoch to reach the convergent result that is shown in figure 7, which the iteration will be stoped if Mean Sum Square Error below than 10<sup>-8</sup>. The weakness of using a few models is that the robustness is achieved if we use the same models for both training and exercise.

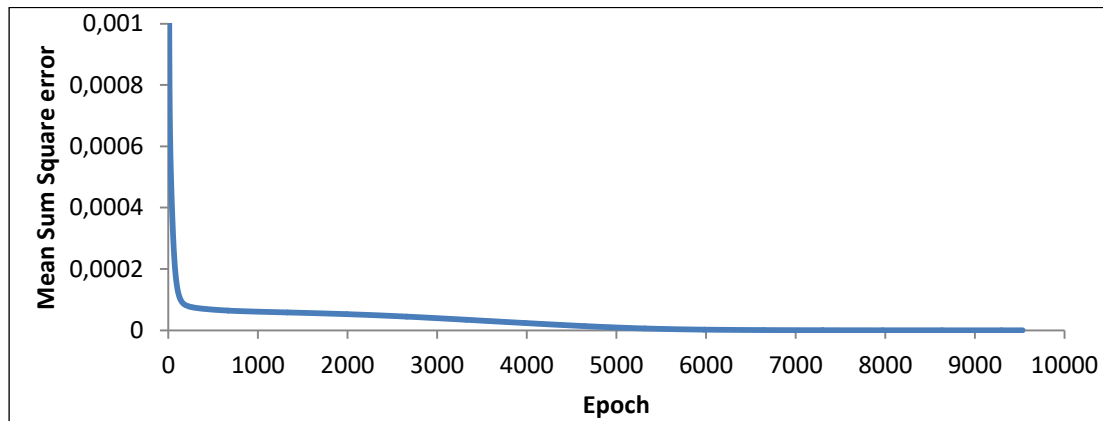

**Figure 7.** Mean Sum Square Error in configuration I.

Comparison between CFD analysis results and Backpropagation results in the configuration I am shown in table 6.

**Table 6.** Coefficient Drag Analysis Comparison

Model	Coefficient Drag CFD Results	Coefficient Drag Back Propagation Results
Model 1	0.78	0.779841
Model 2	0.68	0.680018
Model 3	0.65	0.650124748
Model 4	0.76	0.760261
Model 5	0.68	0.680088
Model 6	0.64	0.639936
Model 7	0.72	0.720002
Model 8	0.8	0.800002
Model 9	0.88	0.879989479

## 6. Conclusion

Based on results from aerodynamics and Backpropagation simulation, it can be concluded below.

1. Based on nine head of high-speed train models simulation using Backpropagation analysis, it is concluded that this research can result in robust weights to compute coefficient drag, which inputs are 4000 coordinates longitudinal nose of high-speed train model.
2. Based on aerodynamics analysis using OpenFoam software, it is known that in a similar shape the longer the long nose of high-speed train the smaller the coefficient drag.
3. Backpropagation algorithm can be used to determine the coefficient drag of high-speed train, thus tom guarantee robustness of weights, it must train using many models.

## References

- [1] Wang, Ruibin., Jianjun, Zhang., Shaojun Bianand., Lihuan, You. (2018).“A survey of parametric modeling methods in high-speed train head design”.Journal of Rail and Rapid Transit. Vol. 232(7), PP. 1965-1983.
- [2] Bistafa, Sylvio R. (2018). “On the development of the Navier–Stokes equation by Navier”. History of Physics and Related Sciences. Revista Brasileira de Ensino de F´ısica, vol. 40, n° 2, e2603 (2018).
- [3] Julpan., Erna Budhiarti Nababan., Muhammad Zarlis. (2015). “ANALISIS FUNGSI AKTIVASI SIGMOID BINER DAN SIGMOID BIPOLAR DALAM ALGORITMA BACKPROPAGATION PADA PREDIKSI KEMAMPUAN SISWA”. Jurnal Teknovasi. Volume 02, Nomor 1, 2015, PP. 103 – 116, ISSN: 2355-701X.

- [4] Chai, T., Draxler, R.R. (2014). “Root mean square error (RMSE) or mean absolute error (MAE)? – Arguments against avoiding RMSE in the literature”. *Geoscientific Model Development Discussion.*, 7, 1247–1250, 2014.
- [5] Balaji, S. Arun. dan Baskaran, K. (2013). “Design and Development of Artificial Neural Networking (ANN) System Using Sigmoid Activation Function to Predict Annual Rice Production in Tamilnadu”. *International Journal of Computer Science, Engineering and Information Technology(IJCSEIT)*. Vol. 3. No.1.
- [6] Anike, Marleni., Suyoto, dan Ernawati. (2012). “Pengembangan Jaringan Syaraf Tiruan dalam Memprediksi Jumlah Dokter Keluarga Menggunakan Backpropagation (Studi Kasus : Regional X Cabang Palu)”. *Seminar Nasional Teknologi Informasi dan Komunikasi (SENTIKA)*.
- [7] Devi, C. J., Reddy, B. S. P., Kumar, K.V., Reddy, B. M., Nayak, N.R. (2012). “ANN Approach for Weather Prediction using Back Propagation”. *International Journal of Engineering Trends and Technology*. Vol. 3. Issue 1.
- [8] Abd Alkader, Shahlla. A., Al-Allaf, Omaima. N. A. (2011). “Backpropagation Neural Network Algorithm for Forecasting Soil Temperatures Considering Many Aspects: A Comparison of Different Approaches”. *The 5th International Conference on Information Technology*.
- [9] Rebello, S., Maheshwari, U., Safreena, Souza, R. V. D. (2011). “Backpropagation Neural Network Method for Predicting Lac Gene Structures in Streptococcus Pyogenes M Group A Streptococcus Strains”. *International Journal for Biotechnology and Molecular Biology Research*. Vol. 2 (4), PP.61-72.
- [10] Gaurang Panchal, Amit Ganatra, Parth Shah, Devyani Panchal. (2011). “Determination Of Over-Learning And Over-Fitting Problem In Back Propagation Neural Network”. *International Journal on Soft Computing (IJSC)*. Vol.2. No.2.